



Sentinel™

Portable Purification System



ENGINEERING YOUR SUCCESS.

Sentinel™

Delivering big results in a compact, lightweight package, the Sentinel is the latest in fluid purification technology from Parker. The system guards over mission critical hydraulic and lubrication systems to effectively attack water, solids and gases while improving equipment health, productivity and reliability.

The smallest in Parker's family of oil purifiers, the Sentinel's unattended automatic operation minimizes energy consumption while extending the usable life of fluids. Equipped with Parker's IQAN MD3 platform control system, the Sentinel provides user confidence in system monitoring while delivering maximum performance on demand.



Typical Markets/ Applications

- **Automotive**
Plastic Injection Molding
Lubrication Systems
- **Power Generation**
Electrohydraulic Control
Systems
- **Marine**
Propulsion
Steering Systems Thrusters
- **Petrochemical**
Lubrication Systems
Process Controls
- **Aerospace**
Ground Support Equipment
Test Stands
- **Mining**
Lubrication Systems

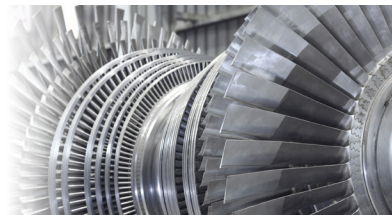

Sentinel™

Features

Compact Size

- Will fit through small doorways
- Makes marine applications possible

Ecoglass Particulate Element

- Coreless, non-metallic constructions
- Environmentally friendly, wasy disposal

Diffusion Head / Manifold

- Flexibility with various fluid viscosities
- Excellent moisture removal efficiency

Forklift Guides / Lifting Eyes

- Safe and secure method of lifting
- Employee safety

Automatic Operation

- Inattended use
- Reduces labor costs
- Increases operation time

Desiccant Breather

- Provides dry, clean air intake
- More efficient operation

316 Stainless Steel

- Used for primary wetted surfaces
- No corrosion
- Product reliability

Reverse Phase Switch

- Enable easy change of motor rotation if out of phase
- Ease of maintenance
- Prevents incorrect rotation

Principles of Operation

Contaminated fluid is drawn through the Sentinel circuit by vacuum. The fluid is subjected to optimum vacuum, temperature and surface area to reduce the boiling point of water and convert water to water vapor. Optimum temperature is achieved with a low watt density heater. Maximum surface area is accomplished by passing the fluid through a unique diffusing column.

The fluid is protected from excessive heat by circulation for a fixed time period. When the pre-set time period is realized, the fluid discharges through high efficiency filtration to the main system reservoir. Water vapor that has been extracted from the system is exposed to a series of coalescers to eliminate any carryover oil vapor in the exhaust stream.

The process repeats until the desired steady state condition is achieved.

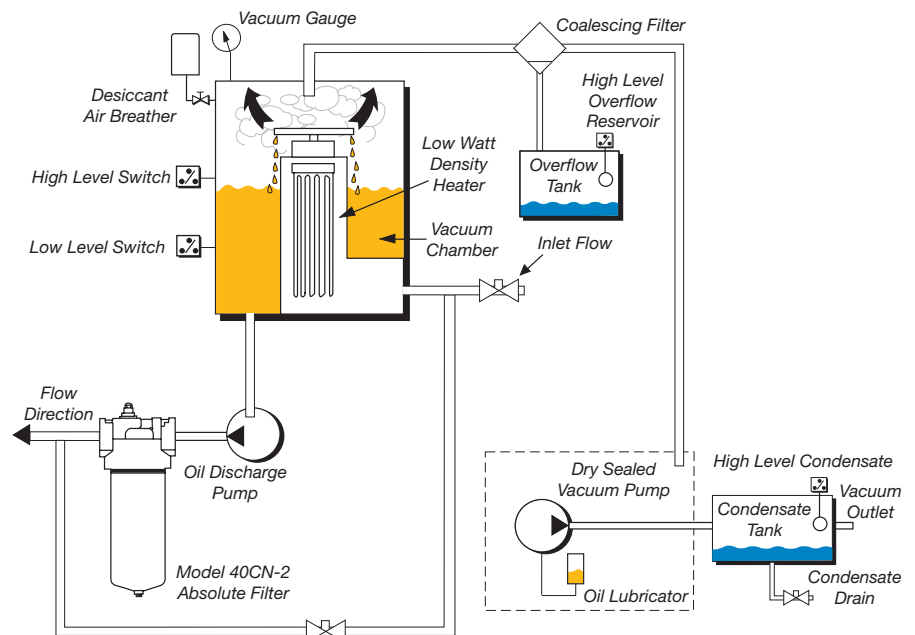

Sentinel™

One of the highlights of the new Sentinel unit is the addition of Parker's IQAN system. The IQAN is an electronic PLC interface that controls many of the operating functions on the Sentinel. With IQAN, the operator can customize set points for various applications within their facility. Some of the user defined set points are:

- **sample rate**
- **moisture high limit**
- **moisture set point (low limit)**
- **temperature**
- **vacuum purge cycle**
- **auto condensate drain**
- **energy conserving features**



Three modes of operation

Standard

Conventional purifiers require that the reservoir fluid be at 150°F before efficient water removal occurs. This could take hours if the ambient temperatures are low and the reservoir volumes are large. Standard mode allows for less power consumption by drawing the fluid through the unit in a unique cyclic method. The fluid is drawn into the unit and held while heat and vacuum act on it to remove water. Every two minutes the fluid is discharged and the process repeats, conserving power that otherwise would be necessary to bring the entire main system reservoir to the required 150°F.



Sentinel

Sentinel mode acts the same as standard mode other than it samples by drawing in fluid from the reservoir and testing the water saturation point. If the level is less than the desired set point, the system will hibernate until the next sampling point. The minimum time between sampling is 20 minutes and the maximum is 12 hours.



Sample

Once started, three batches of hydraulic fluid will be drawn into the system where overall moisture level and temperature are averaged and displayed on the IQAN screen.



Sentinel™

Specifications

Flow Rate	5 gpm (18.9 lpm)
Dimensions	45" H x 19.5" W x 24" L (1143mm x 495mm x 686mm)
Weight	440 lbs. (200 kg)
Seal material	Fluorocarbon
Condensate tank	.5 gal (1.9 ltrs)
Dispersal elements	1
Minimum operating capacity	5 gal (18.9 ltrs)
Vacuum (max)	24 In/Hg
Viscosity (max)	2150 SUS (460 cSt)
Outlet pressure (max)	60 psi (4.1 bar)
Ports	3/4" JIC (male) inlet 3/4" JIC (male) outlet
FLA (full load amps)	16 amps @ 480VAC
Shipping Weight	640 lbs. (290 kg) maximum
Shipping Dimensions	56" H x 37" W x 37" L (1422mm x 940mm x 940mm)

Electrical Requirements:

230VAC, 3P, 60Hz
380VAC, 3P, 50Hz
415VAC, 3P, 50Hz
460VAC, 3P, 60Hz
575VAC, 3P, 60Hz

Electrical Connection Port:

NEMA L16-30P Flanged Inlet

Hydraulic Connections:

Inlet: JIC 12
Outlet: JIC 12
Max Flow: 5 GPM
Water Drain: JIC 8

Vacuum Exhaust Port: JIC 8

Max Pressure: 60 psi (gauge)

Vibration: Band 1: 900 hz .5 g*g/Hz

Storage: Max Temp 180°F, 100% rh

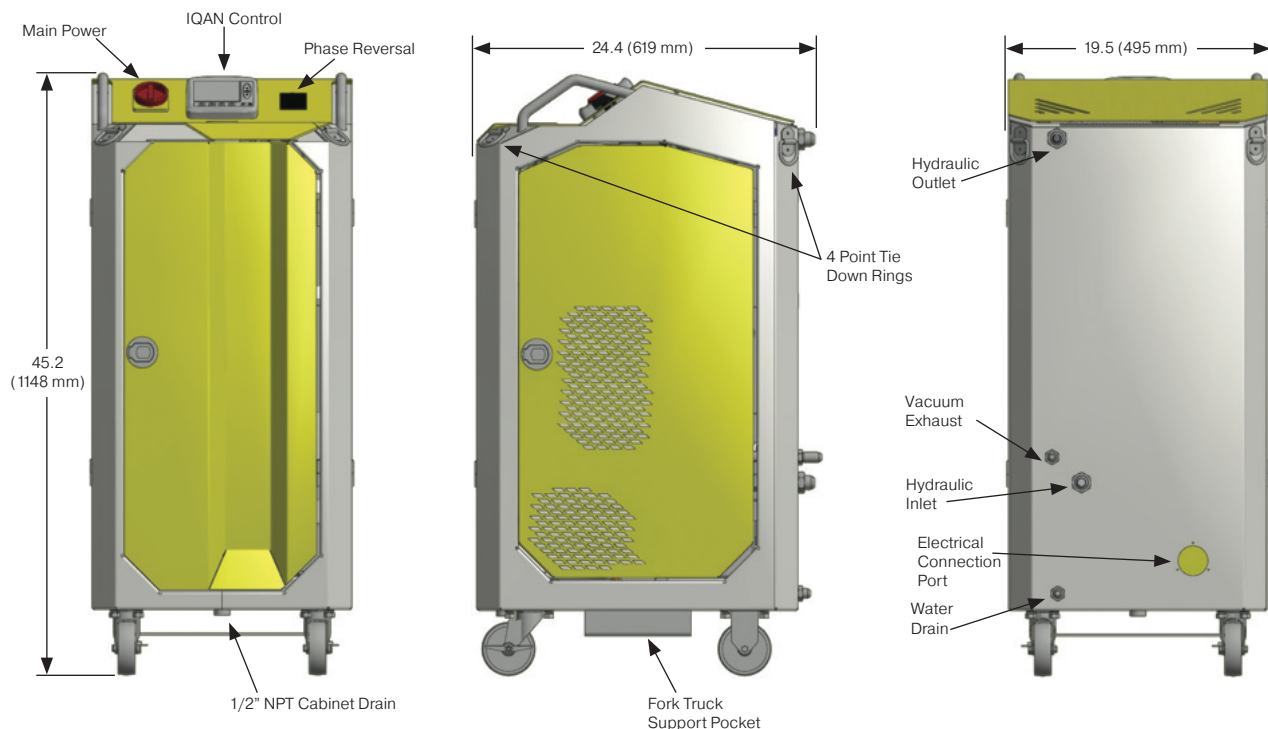

Note: Dimensions and weights are approximate and are for reference only.

Sentinel™

Specifications



Potential Contaminant	Sentinel Performance
Solid particulate	ISO Cleanliness Code 14/13/10 Attainable
Water	Removes 100% of free water, 90% of dissolved water
Air/Gases	Removes 100% of free air and gases, 90% of dissolved air and gases

Typical Performance	
Tank Size	55 gallon test drum
Run Time	16 hours
Fluid Type	Hydraulic
Water Content	Start: 7,000+ ppm (1%) Saturation pt: 5,000 ppm Stop: 200 ppm (0.005%)

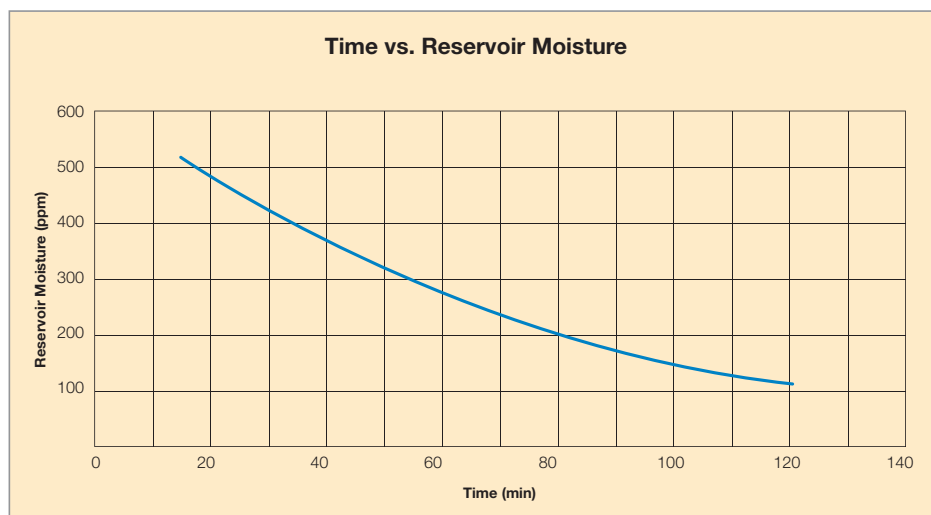
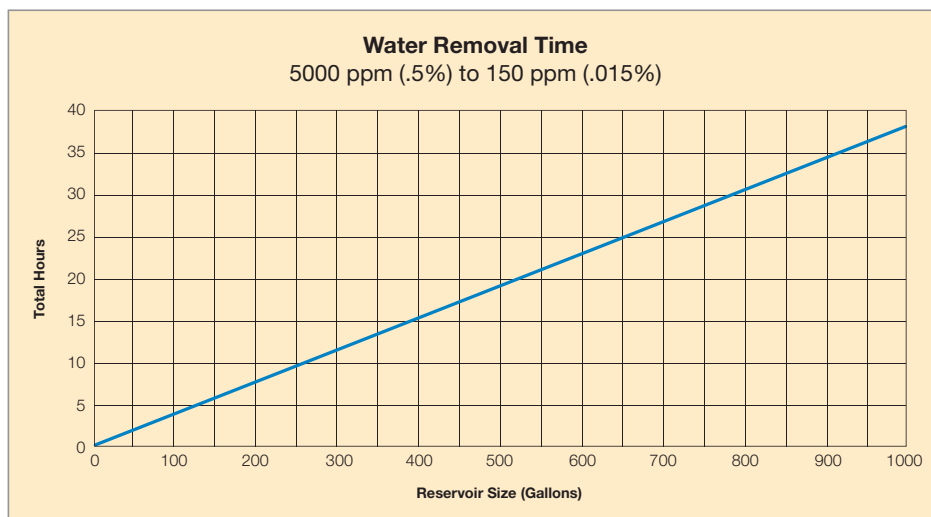

Ordering

Part Number	Description
Standard Unit	
943118*	230VAC, 3P, 60Hz
943116*	380VAC, 3P, 50Hz
943494*	415VAC, 3P, 50Hz
943213*	460VAC, 3P, 60Hz
945341*	575VAC, 3P, 60Hz
Optional Accessories	
943236	Mounting Bracket Kit
943238	Cordset (pigtail end)
Service Parts	
936711Q	Hydraulic Particulate Element
943237	Service Kit (includes TriCeptor air breather, hydraulic particulate element, coalescing element, vacuum pump oil and vacuum pump filter element)
20072409	IQAN MD3
B-10235-0-460	Heater 460VAC
B-10235-0-380	Heater 380VAC
B-10235-0-230	Heater 230VAC
CEM3546T	Hydraulic Pump Motor
06F20C2218A1FPH80	Condensate Drain Valve
00424	Float Switch
MPS-V33N-PGAT	Vacuum Sensor
2820008	Pressure Sensor
40CN205QEVE2GS164	Filter
MS1504	Moisture Sensor
3349116565	Gear Pump

* Standard unit includes

Dry sealed vacuum pump, Coalescing filter, 5 micron Ecoglass element, 6KW 3 phase low watt density heater, 3" diameter rubber-wheel casters, Consult factory for other options

Sentinel Specification Worksheet

Customer Name & Address: _____

Market & Application (i.e. Power Gen/Turbine Lube) _____

Fluid Type: _____ Brand: _____ Grade: _____

Viscosity: Min: _____ SUS/cSt @ _____ °F/°C

Max: _____ SUS/cSt @ _____ °F/°C

Normal: _____ SUS/cSt @ _____ °F/°C

Critical Hydraulic Component Types: (Check all that apply)

- | | |
|--|--|
| <input type="checkbox"/> Servo Valves | <input type="checkbox"/> Proportional Valves |
| <input type="checkbox"/> Vane and piston pumps/motors | <input type="checkbox"/> Gear pumps/motors |
| <input type="checkbox"/> Directional & pressure control valves | <input type="checkbox"/> Flow control valves |

Water concentration: Current % of water _____

Desired % of water _____

Sentinel/PVS location related to reservoir (reservoir above or below ground level & distance)

- 0-5 meters 5-10 meters ≥10 meters

System fluid operating temperature: _____ °F/°C

Voltage options: 230 VAC, 3P 60Hz 380 VAC, 3P 50Hz 415 VAC, 3P 50Hz

460 VAC, 3P 60Hz 575 VAC, 3P 60Hz

System Volume: 0-1000 gal - Sentinel or PVS185 1000-3000 gal - PVS600

3000-7000 gal 7000-9000 gal

>9000 gal

Any previous filtration problems with the application?

- Gelling High contamination levels High ambient environment

Sentinel model selected: _____



Hydraulic & Fuel Filtration Division
www.parker.com/emhff

Last updated August 4th, 2023

Parker's willingness to conduct business with Buyer is expressly conditioned on Buyer's assent to Parker's Offer of Sale. www.parker.com/saleterms