



MPD Series

Medium Pressure Duplex Filters



ENGINEERING YOUR SUCCESS.

MPD Series

Applications

- **Circulating Lube Oil Systems**
- **Power Generation Control Systems**
- **Steel Mill Control Systems**
- **Pulp & Paper Control Systems**
- **Test Stands**
- **Automotive Stamping Presses**
- **Offshore & Land Based Oilfield Applications**

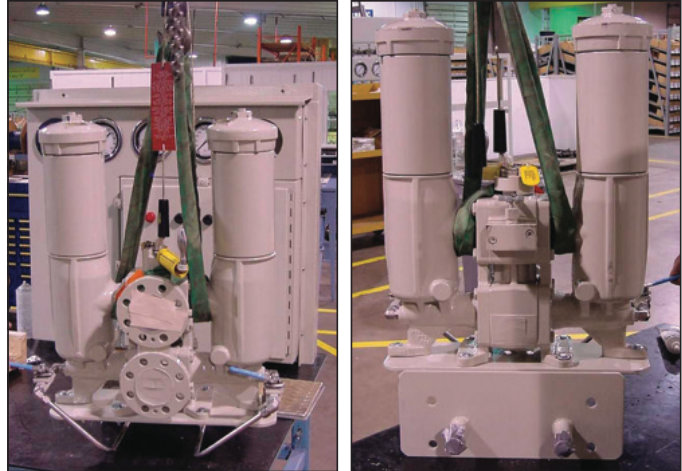

MPD series filters are an outstanding choice for today's demanding hydraulic control and circulating oil systems.

The MPD's innovative modular design, rugged ductile iron construction and coreless element technology, combined with many other features, provide solutions across a broad range of industrial applications.

The Modular design provides user flexibility for simplex or duplex applications. Incorporating side chambers as simplex filters along with duplex installations provide common elements across the circuit design.

Construction features like full ported transfer valve with neutral center flow capability offer tremendous benefit in cold start conditions. Standard features like pressure sensing taps, vents, drains and internal pressure equalization make this product incomparable in industry.

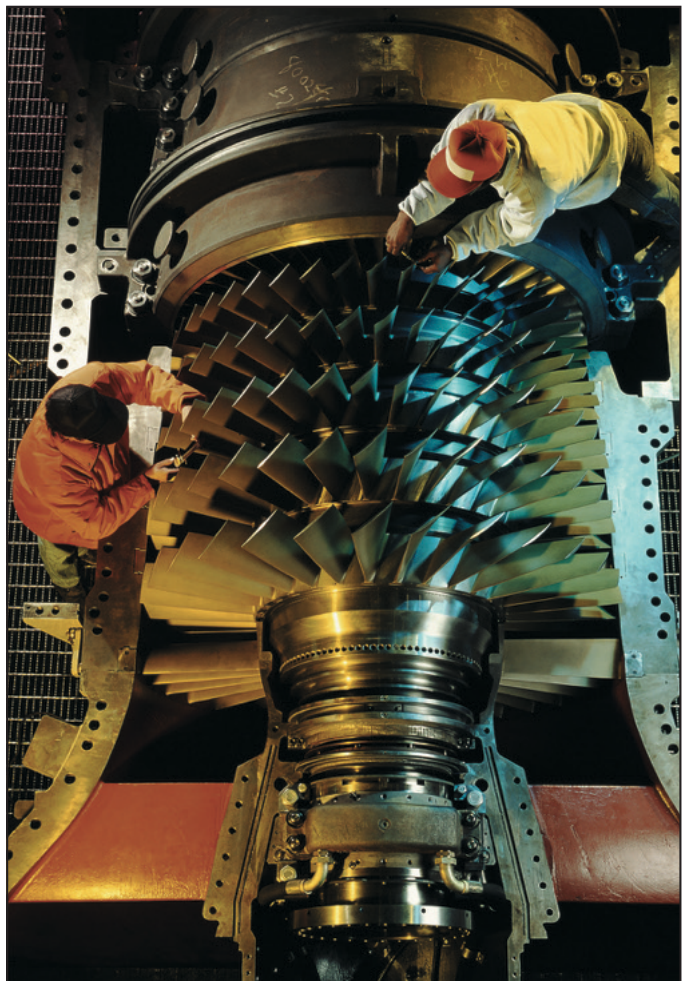

MPD Series

Features

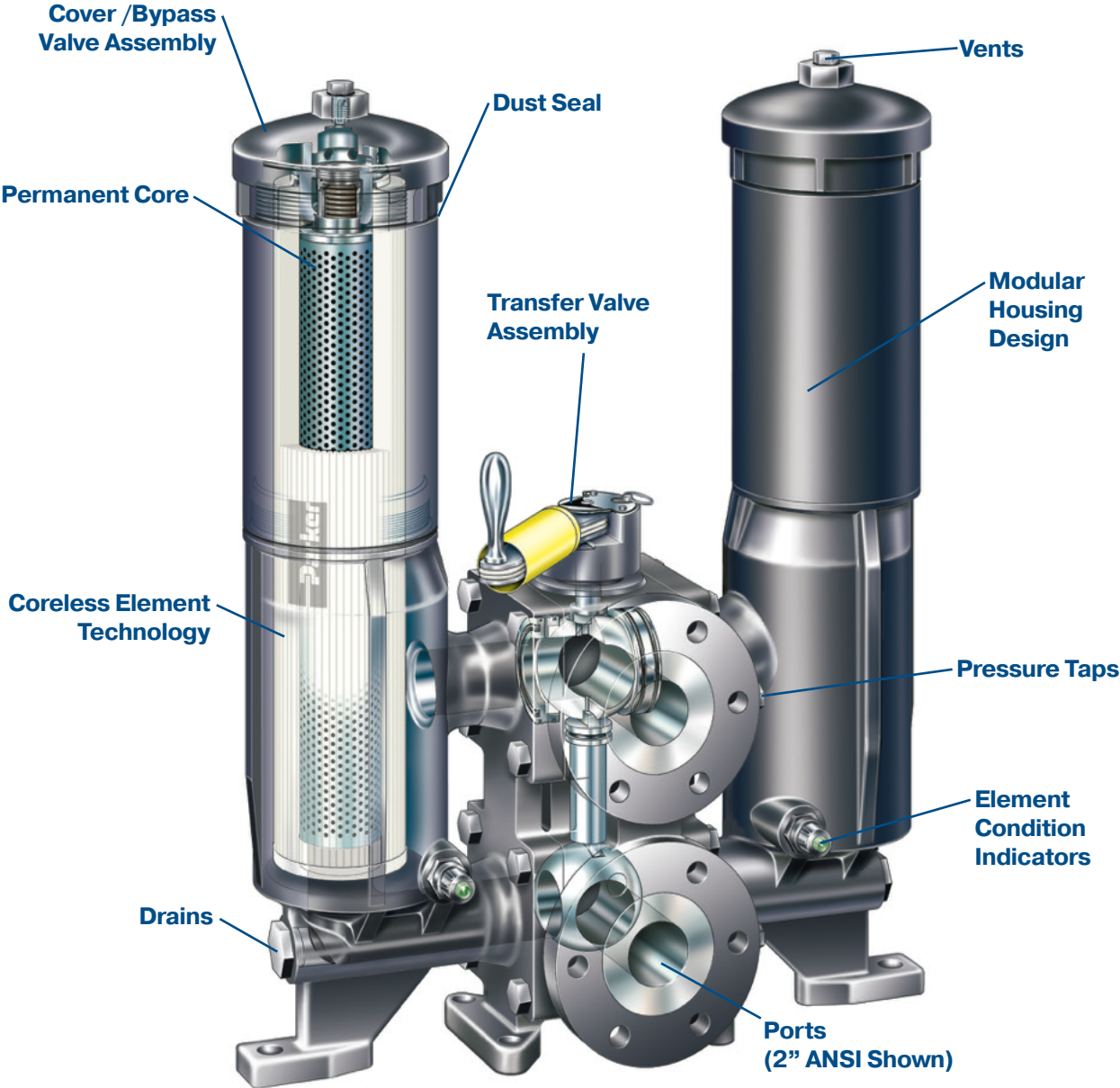

MPD Series

MPD-1 Element Performance

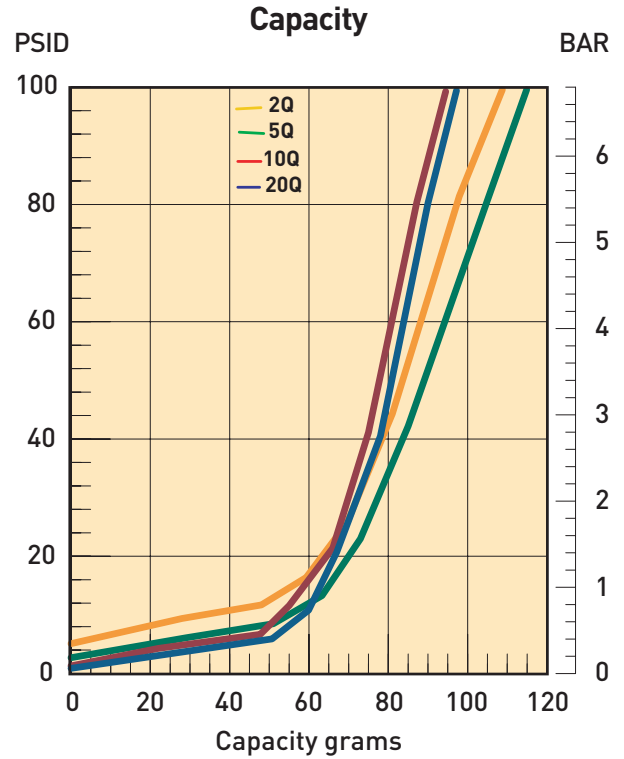
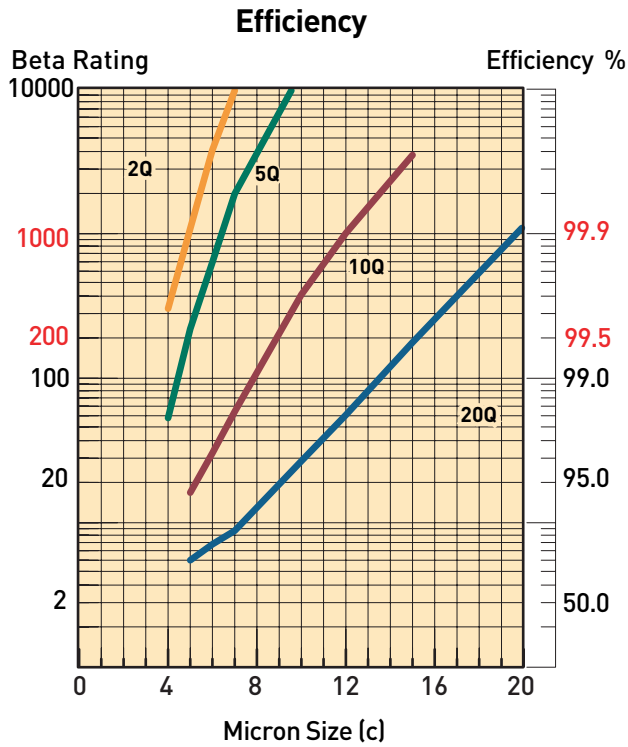

Results typical from Multi-pass tests run per test standard ISO 16889 @ 50 gpm to 100 psid terminal - 10 mg/L BUGL
Refer to Appendix for relationship to test standard ISO 4572.

Flow vs. Pressure Loss

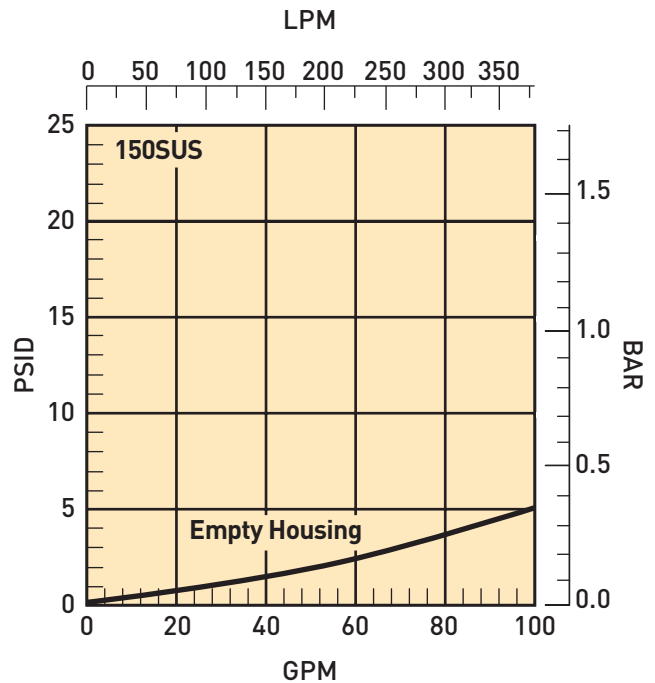
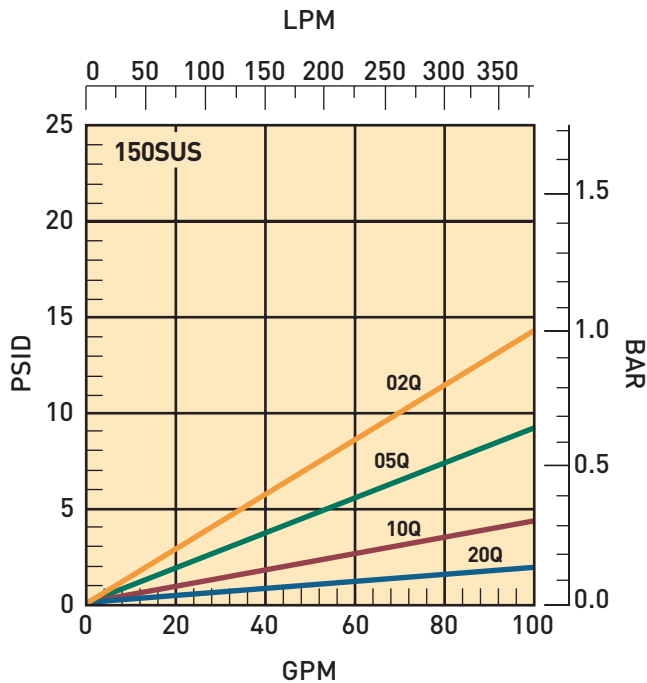

MPD Series

MPD-2 Element Performance

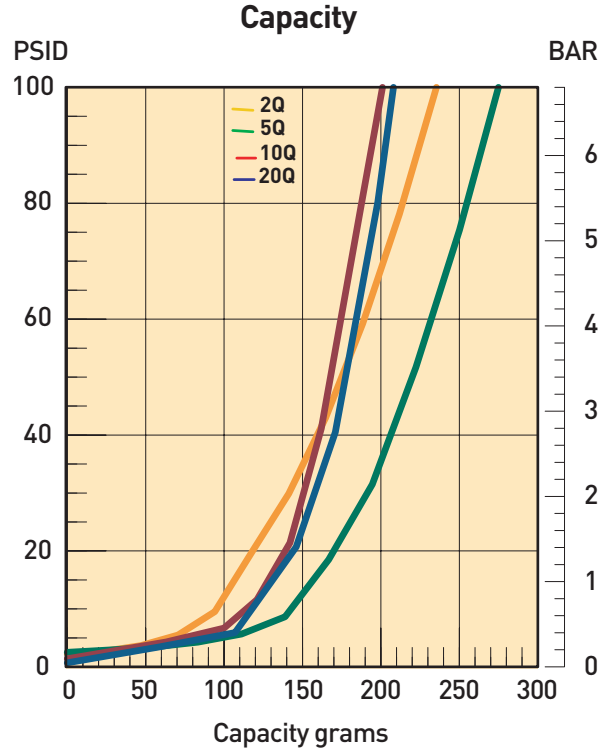
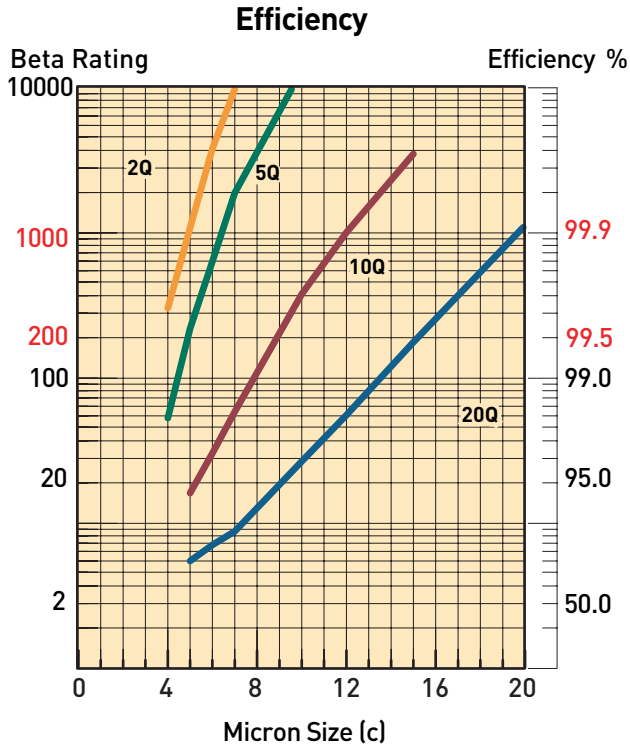

Results typical from Multi-pass tests run per test standard ISO 16889 @ 80 gpm to 100 psid terminal - 10 mg/L BUGL
Refer to Appendix for relationship to test standard ISO 4572.

Flow vs. Pressure Loss

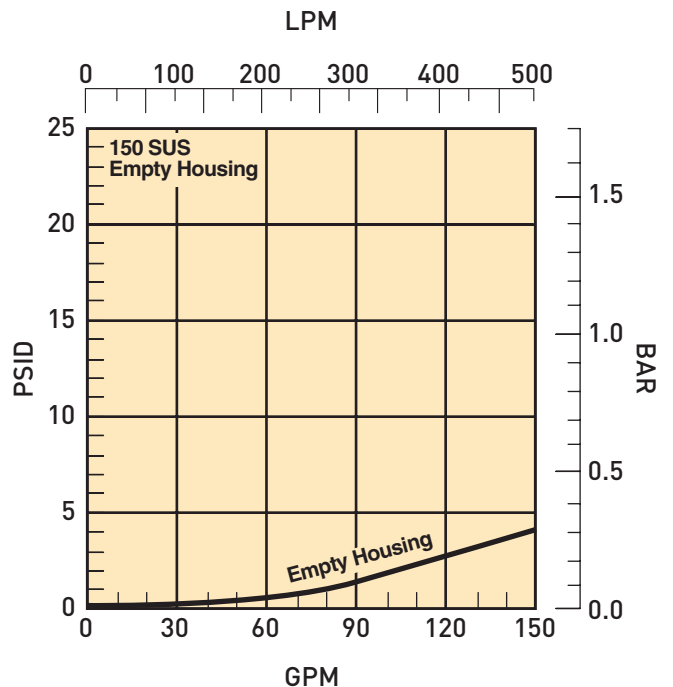
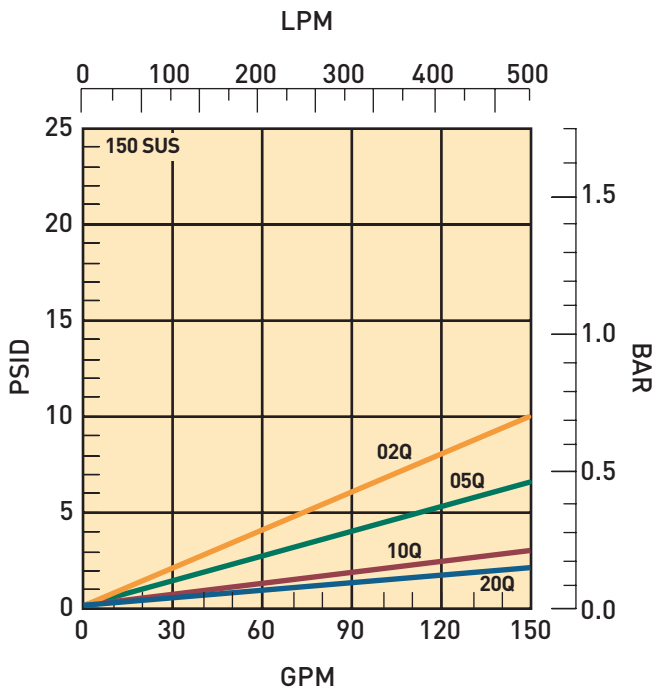

MPD Series

Replacement Elements

Microglass Replacement Elements

The unique multi-layer design combines high efficiencies with exceptional dirt holding capacities for performance that is unequalled in the industry today. This performance is further enhanced in the MPD series with the introduction of the deep pleat design. The deep pleat element design increases the amount of media in the element and therefore increases capacity.

With Microglass, you do not have to make a compromise between efficiency and capacity; you can have both.

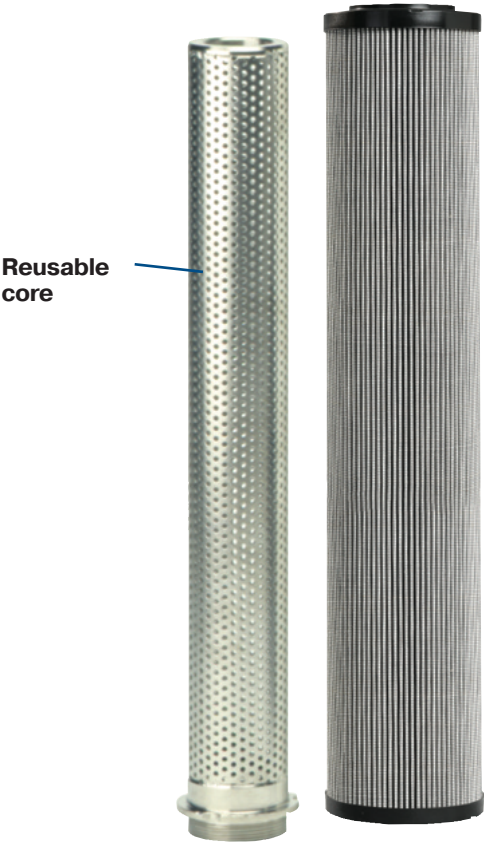

Feature	Advantage	Benefit
Modular design filter	<ul style="list-style-type: none"> Use a simplex or duplex 	<ul style="list-style-type: none"> Reduced installation due to common elements Application flexibility
Top access cover	<ul style="list-style-type: none"> Remove element from top Lighter than removing entire bowl 	<ul style="list-style-type: none"> No oil mess
Visual and electrical indicators	<ul style="list-style-type: none"> Know exactly when to service elements 	<ul style="list-style-type: none"> Keeps system clean
Drain port	<ul style="list-style-type: none"> Drain all oil from assembly prior to servicing 	<ul style="list-style-type: none"> Eliminates cross contamination
Vent port	<ul style="list-style-type: none"> Purges all trapped air in filter 	<ul style="list-style-type: none"> Get the maximum performance from elements
Multipass tested elements (per ANSI/NFPA T3.10.8.8 R1-1990)	<ul style="list-style-type: none"> Element performance backed by recognized test standards 	<ul style="list-style-type: none"> Elements selected will have consistent performance levels
Microglass Elements	<ul style="list-style-type: none"> Multi-layer media Coreless as standard HF4 as option 	<ul style="list-style-type: none"> High capacity with high efficiency No performance loss from pleat bunching
Equalizing valve & manifold	<ul style="list-style-type: none"> No external plumbing 	<ul style="list-style-type: none"> Safety & reliability
Upstream & downstream sensing ports	<ul style="list-style-type: none"> Add additional instrumentation 	<ul style="list-style-type: none"> Product flexibility

MPD Series

Specifications

Pressure Ratings:

Maximum Allowable Operating Pressure (MAOP):

- 3000 psi (206.9 bar) SAE port — MPDH only
- 1200 psi (81.6 bar) SAE port;
- 500 psi (34 bar) ANSI port

Rated Fatigue Pressure:

- 3000 psi (206.9 bar) SAE port — MPDH only
- 1200 psi (81.6 bar) SAE port;
- 500 psi (34 bar) ANSI port

Design Safety Factor: 3:1

*Consult factory for higher operating pressures

Operating Temperatures:

-15°F (-26°C) to 160°F (71°C)

*Consult factory for temperatures outside specified range

Element Collapse Rating:

Standard: 150 psid (10.3 bar)

High collapse Microglass only:

- 1200 psid (81.6 bar) (SAE);
- 500 psid (34 bar) (ANSI)

Materials:

Transfer Valve: Ductile Iron

Side Chamber: Ductile Iron

Side Chamber Extension: Steel

Cover: Ductile Iron (MPD), Carbon Steel (MPDH)

Equalizing Valve and Manifolds: Steel

Shipping Weights (approximate):

MPD-1: 215 lbs. (98 kg)

MPD-2: 285 lbs. (129 kg)

Element Condition Indicators:

Type M2 Series: Visual, auto-resetting with a red indication at the designated differential pressure. In the clean condition, indication is green.

Type E Series: Electrical/Visual, auto-resetting with a red indication at the designated differential pressure. In the clean condition, indication is green. Rated 5 Amps at 125/250 VAC; 5 Amps resistive, 3 amps inductive (sea level) at 28 VDC; SPDT.

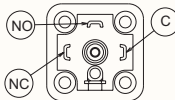
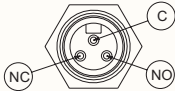
'E' Series Electrical Indicator Connector Chart		
Connector	Model Coding	Wiring / Male Connector
DIN 43650 3 pole + earth DIN 50005 plug pin code	e2	
3 pin ANSI/B93.55m (dimensions only)	E3	

Type H Series: Heavy duty electrical/no visual, rated 0.25 Amps resistive, 12 to 28 VDC and .25 Amps resistive, 110-175 VAC; 5 watts; SPDT.

'H' Series Electrical Indicator Connector Chart		
Connector	Model Coding	Wiring / Male Connector
½"-14 NPT conduit adapter w/24" wire leads (for all light to heavy conduit uses)	H	Black (NO), Blue (NC), and White (C)
None: 12" wire leads only	H1	Black (NO), Blue (NC) and White (C)

No indicator P option: plugged indicator port.

Contact factory for other available indicator options & types.

Element Servicing Instructions

The system does not need to be shut down to service elements; however, pressure must be equalized at both side chambers of the duplex filter before performing transfer valve changeover.

1. Black flow arrow on top of the transfer valve points to the on-duty chamber.
2. Open the equalizing valve (counter-clockwise) to balance pressure at the side chambers.
3. Shift directional lever on the ratchet handle to switch the ratchet direction.
4. Pull detent ring up to disengage the locking pin and allow handle to rotate.
5. Rotate ratchet handle back and forth over the inlet port until the transfer valve is fully shifted and the detent locking pin engages.
6. Black flow arrow now points to the new on-duty side chamber.
7. Close equalizing valve (clockwise) to isolate the side chambers.
8. Loosen new off-duty vent plug (counter-clockwise) approximately 2 turns. Do not thread out complete.
9. Remove drain plug (counter-clockwise) from new off-duty chamber to lower oil level.
10. Remove new off-duty chamber cover by rotating (counter-clockwise) until unthreaded then lift from chamber.
11. Pull element out from chamber. Discard used disposable elements as they are not cleanable.
12. Install new element by centering it on the element locator in the bottom of the chamber and pushing down into place.
13. Inspect cover o-rings and replace if necessary.
14. Install cover onto the chamber by rotating clockwise) and tightening to 90-100 ft.-lbs.
15. Install and tighten drain plug (clockwise) to 60-70 ft.-lbs.
16. Open equalizing valve (counter-clockwise) to purge air from the new off-duty chamber.
17. When oil flows from the vent close the equalizing valve (clockwise).
18. Tighten new off-duty vent plug (clockwise) to 15-20 ft.-lbs.

MPD Series

Specifications

ANSI Dimensional Drawing

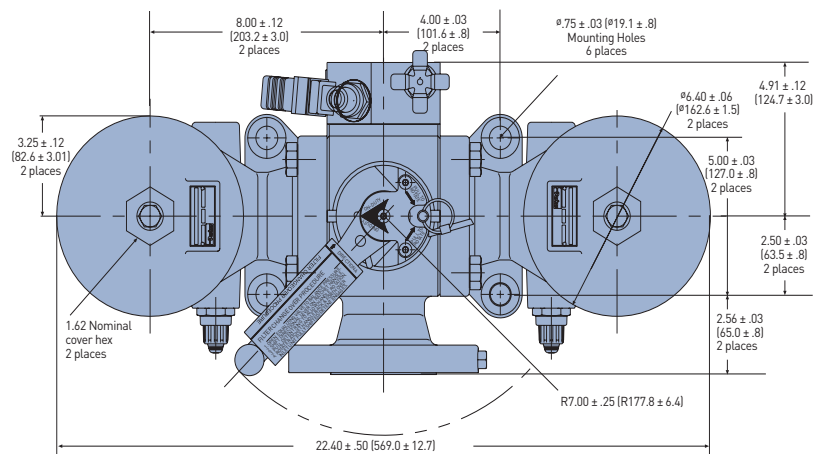

Linear Measure: inch [millimeter]

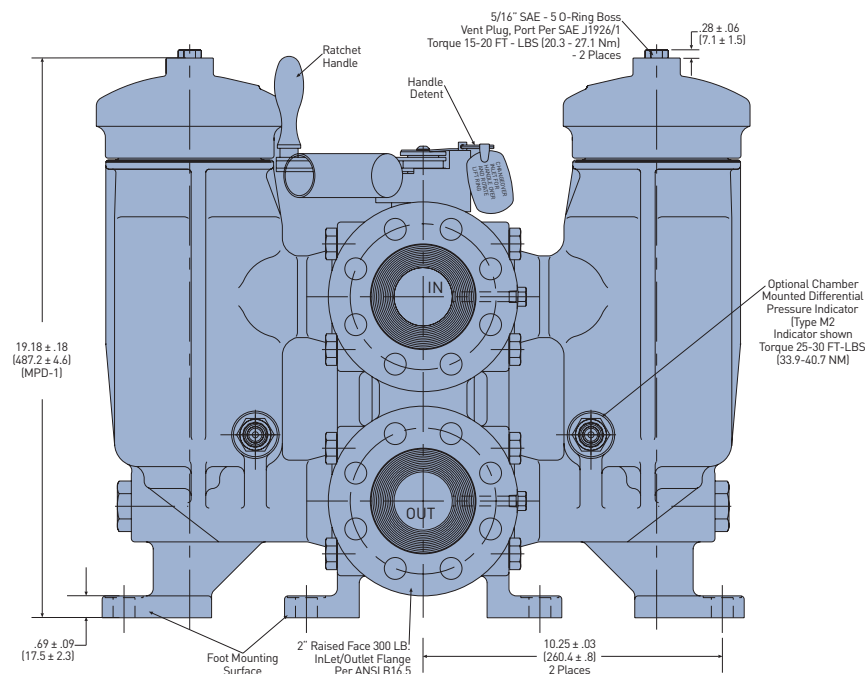
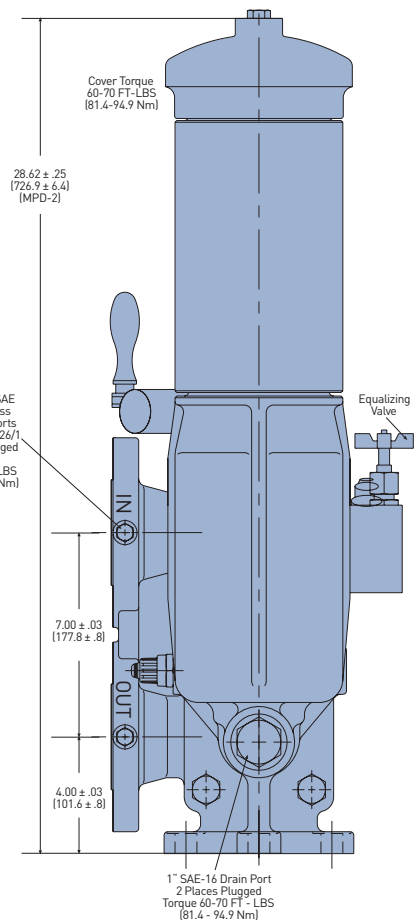

Drawings are for reference only.
Contact factory for current version.

MPD Series

Specifications

SAE Dimensional Drawing

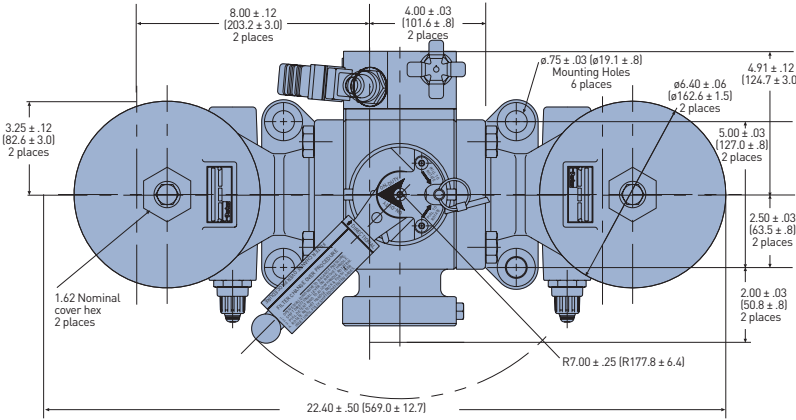

Linear Measure: inch [millimeter]

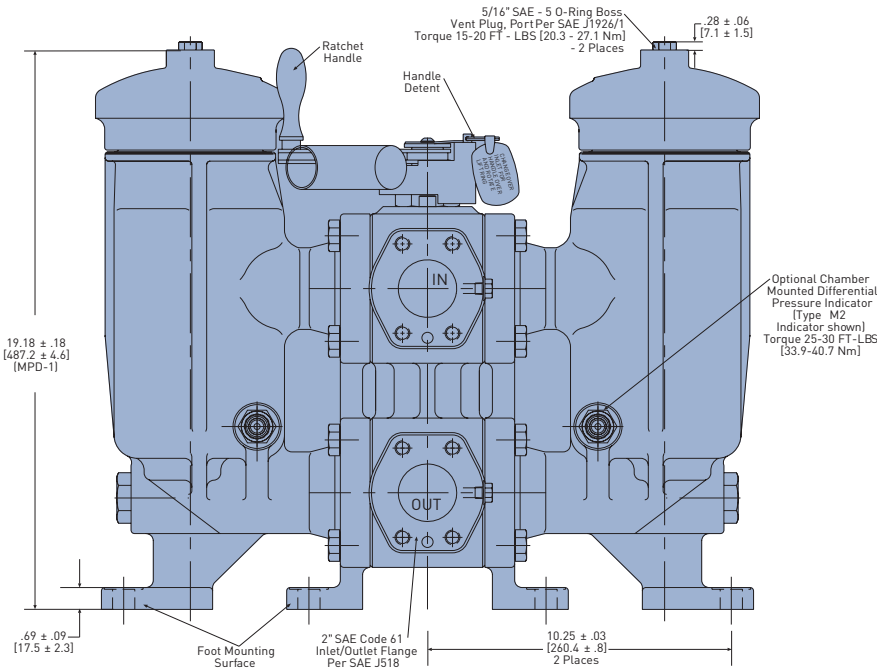
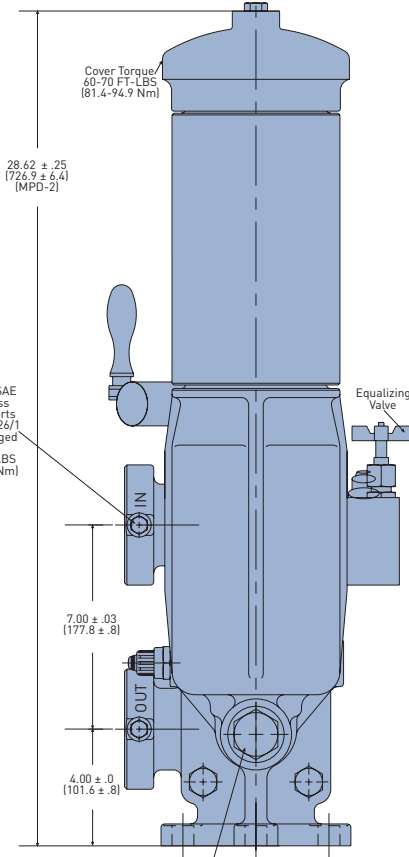

Drawings are for reference only. Contact factory for current version.

MPD Series

Parts List

In- dex	Description	Element Type	
		Ecoglass	Microglass
1	Cover Assembly		
	w/ 25 psi bypass	935964	935964
	w/ 50 psi bypass	935965	935965
	w/ no bypass	935966	935966
2	Cover (O-ring & Dust seal)	V72247	V72247
3	Cover backup ring	935419	935419
4	Indicator		
	P option - plugged port	925515	925515
	M2 25 psi	932026	932026
	M2 50 psi	932027	932027
	E2 25 psi	931153	931153
	E2 50 psi	929599	929599
	E3 25 psi	932773	932773
	E3 50 psi	929596	929596
	H 25 psi	933053	933053
	H 50 psi	932905	932905
H1	25 psi	933054	933054
	50 psi	932906	932906
5	Element	see chart on model code page	

In- dex	Description	Element Type	
		Ecoglass	Microglass
6	Vent plug	935466	935466
7**	Vent plug o-ring	V93905	V93905
8	Drain plug w/ o-ring	928364	928364
9	Pressure tap plug w/ o-ring	928882	928882
10**	Equalizing valve	928118	928118
11	Transfer valve assembly		
	ANSI 2" w/ indicator port	935968	935968
	SAE 2" w/ indicator port	935969	935969
12	Housing assembly		
	right side w/ indicator port	935970	935972
	right side w/o indicator ports	935974	935975
	left side w/ indicator port	935971	935973
	left side w/o indicator ports	935974	935975
13	Housing extension (MPD-2)	935489	935489
14	5/8" - 11x1-3/4" HHCS	922812	922812
15**	Seal kit - transfer valve	Consult Factory	
16**	Seal kit - housing assembly	Consult Factory	

* Consult factory for MPDH components

** Not Shown

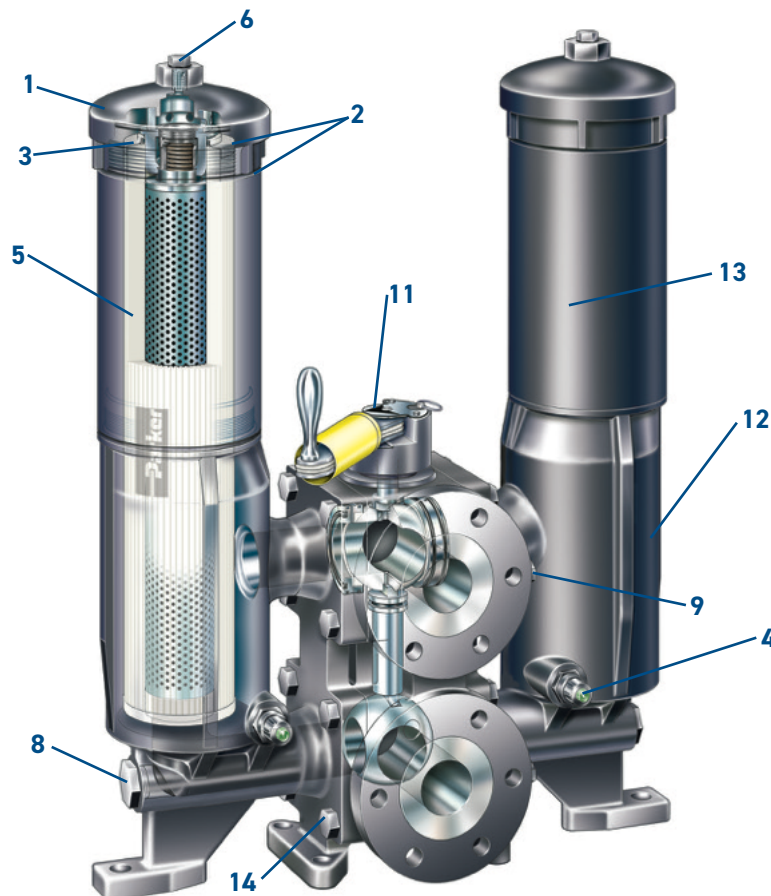

MPD Series¹

Medium Pressure Duplex Filters

How To Order

Select the desired symbol (in the correct position) to construct a model code. Example:

BOX 1	BOX 2	BOX 3	BOX 4	BOX 5	BOX 6	BOX 7	BOX 8
	MPD	1	10QE	NE2	25	B2	1

BOX 1: Seal Material	
Symbol	Description
None	Nitrile
F3	Fluorocarbon

BOX 2: Filter Series	
Symbol	Description
MPD	Duplex Filter 1200 psi
MPDH	Duplex Filter 3000 psi

BOX 3: Element Length	
Symbol	Description
1	Single
2	Double

BOX 4: Media Code	
Symbol	Description
02QE	Microglass, 2 micron
05QE	Microglass, 5 micron
10QE	Microglass, 10 micron
20QE	Microglass, 20 micron

BOX 5: Indicator	
Symbol	Description
Side Chamber	
N	No indicator; no pressure port
P	Indicator, port only
M2	Visual auto reset
E2	Electrical w/ DIN 43650 connector
Equalizing Valve Manifold	
P	Port plugged
M2	Visual auto reset
E2	Electrical w/ DIN 43650 connector

BOX 6: Bypass	
Symbol	Description
25	25 PSI (1.7 bar)
50	50 PSI (3.5 bar)

BOX 7: Ports	
Symbol	Description
B2	2" 300 lb RF ANSI flange (500 psi)
Y9	2" SAE 4 bolt Code 61 flange face

BOX 8: Options	
Symbol	Description
1	None
11	No bypass

1. Filters include the element you select already installed.

Replacement Elements²

Media	MPD-1	MPD-2
02QE	935516Q	935488Q
05QE	935517Q	935458Q
10QE	935518Q	935520Q
20QE	935519Q	935521Q

2. Elements have fluorocarbon seals.



Hydraulic & Fuel Filtration Division
www.parker.com/emhff

Last updated August 4th, 2023

Parker's willingness to conduct business with Buyer is expressly conditioned on Buyer's assent to Parker's Offer of Sale. www.parker.com/saleterms