



Desiccant Breathers

Defends against moisture and particulate contamination



ENGINEERING YOUR SUCCESS.

Desiccant Breathers

Applications

- Reservoirs
- Mobile Equipment
- Gearboxes
- Transformers
- Storage Tanks
- Totes
- 55 Gallon Drums

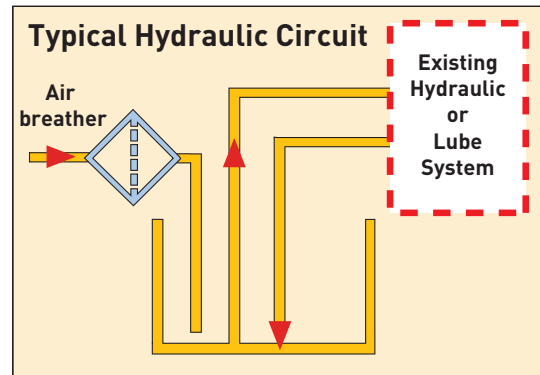

The Hydraulic and Fuel Filtration Division’s desiccant breather portfolio offers a wide selection of breather designs and desiccant types to deliver optimum performance. Reservoirs open to atmosphere are subject to an array of ambient conditions and require clean dry air on demand.

	<p>EZ Dri <i>Zeolite Breather</i></p>	<ul style="list-style-type: none"> • Reduces head space Relative Humidity to as low as 5% • Excellent temperature resistance for >100°F applications • Color indicating beads provide visual identification for service on demand
	<p>TriCeptor <i>Silica Gel Breather</i></p>	<ul style="list-style-type: none"> • Reduces head space Relative Humidity to as low as 20% • Excellent performance in high humidity (>40% RH) environments • Color indicating desiccant provides visual identification for service on demand
	<p>Mobile <i>Rugged Breather</i></p>	<ul style="list-style-type: none"> • EZ Dri or TriCeptor options available • Clean, dry air on demand via high flow check valves to maximize breather life • Rugged construction to withstand the most demanding service
	<p>TriCeptor Plus <i>80% Silica Gel 20% Zeolite</i></p>	<ul style="list-style-type: none"> • Clean, dry air on demand via high flow check valves to maximize breather life • Mixed desiccant provides the ultimate application flexibility • Reduces head space Relative Humidity to as low as 5% • Color indicating desiccant provides visual identification for service on demand
	<p>TriCeptor Extended <i>80% Silica Gel 20% Zeolite</i></p>	<ul style="list-style-type: none"> • Double the capacity of a standard breather • Clean, dry air on demand via high flow check valves to maximize breather life • Mixed desiccant provides the ultimate application flexibility • Reduces head space Relative Humidity to as low as 5% • Color indicating desiccant provides visual identification for service on demand • Integrated oilmist coalescer protects the desiccant from hydrocarbon contaminants
	<p>ClearConnect <i>Wired Relative Humidity Sensor</i></p>	<ul style="list-style-type: none"> • Relative humidity sensor provides realtime system monitoring • Clean, dry air on demand via high flow check valves to maximize breather life • Standard or extended sizes to meet desired service intervals • Clear silica gel desiccant offers up to a 20% improvement in absorption capacity

Desiccant Breathers

Selection Guide

Features	EZ Dri	TriCeptor	EZ Dri Mobile	TriCeptor Mobile	TriCeptor Plus	TriCeptor Extended	ClearConnect
Zeolite	X		X	X	X	X	
Color Indicating Silica Gel		X		X	X	X	
Clear Silica Gel							X
Mechanical Adsorption		X		X	X	X	X
1" Multi Fit Threaded Connection	X	X			X		X
1" FNPT Connection						X	X
1 1/2" SAE Connection			X	X			
Clean Air on Demand via high flow check valves				X	X	X	X
Wired Relative Humidity Sensor							X
Rugged Construction			X	X			
Increased Desiccant Volume						X	X
External Ribbing for Change Out	X	X			X		X
Integrated Stand Pipe	X	X	X	X	X	X	X
Honeycomb to Capture Oil Mist						X	X
Headspace RH% Minimized (<5%)	X		X		X	X	
Good for low humidity environments (<40%)	X		X		X	X	
Good for high humidity environments (>40%)		X		X	X	X	X

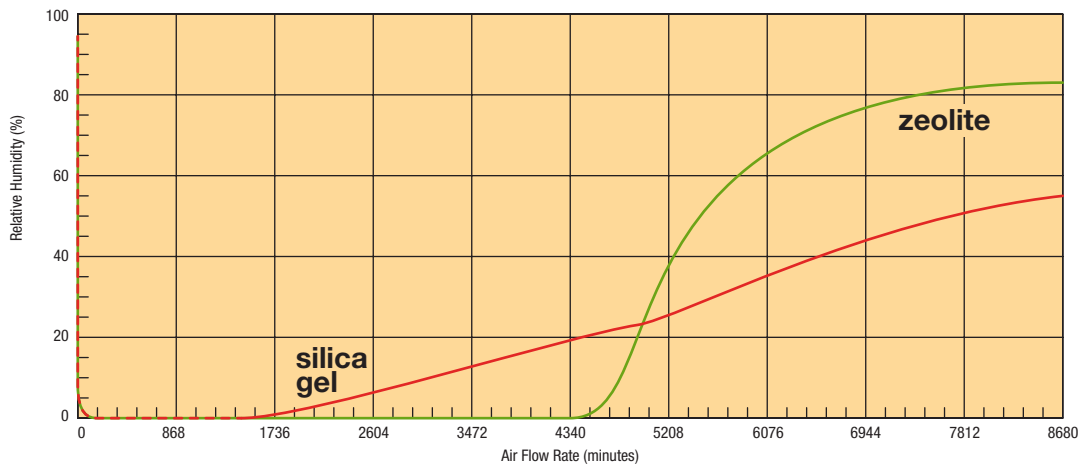
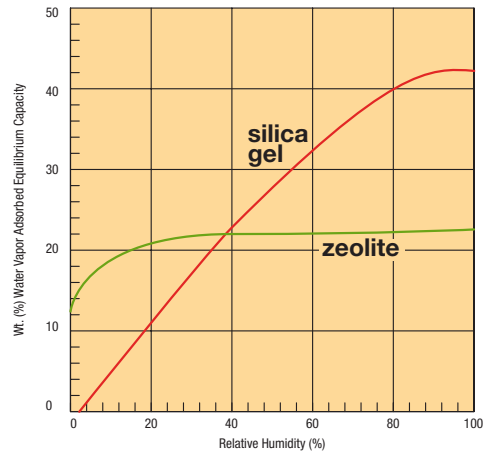
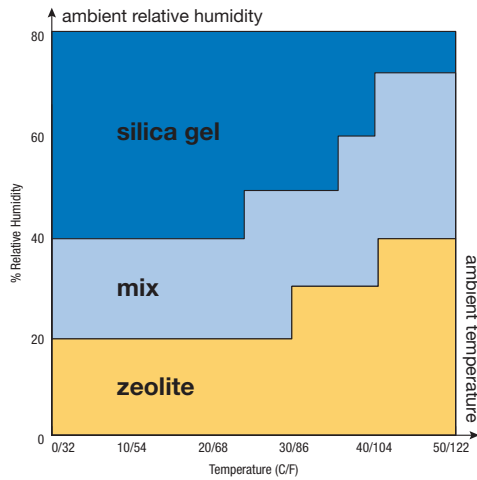

E Z Dri

Features

Materials:

Housing: Polycarbonate, Nylon 6/6 30% Glass Filled, Polypropylene

Filter Efficiency: 3 μ absolute ($\beta_3 \geq 200$)

Operating Temperatures: -20°F (-29°C) to 200°F (93°C)

Seals: Nitrile, PVC



Active

Replace

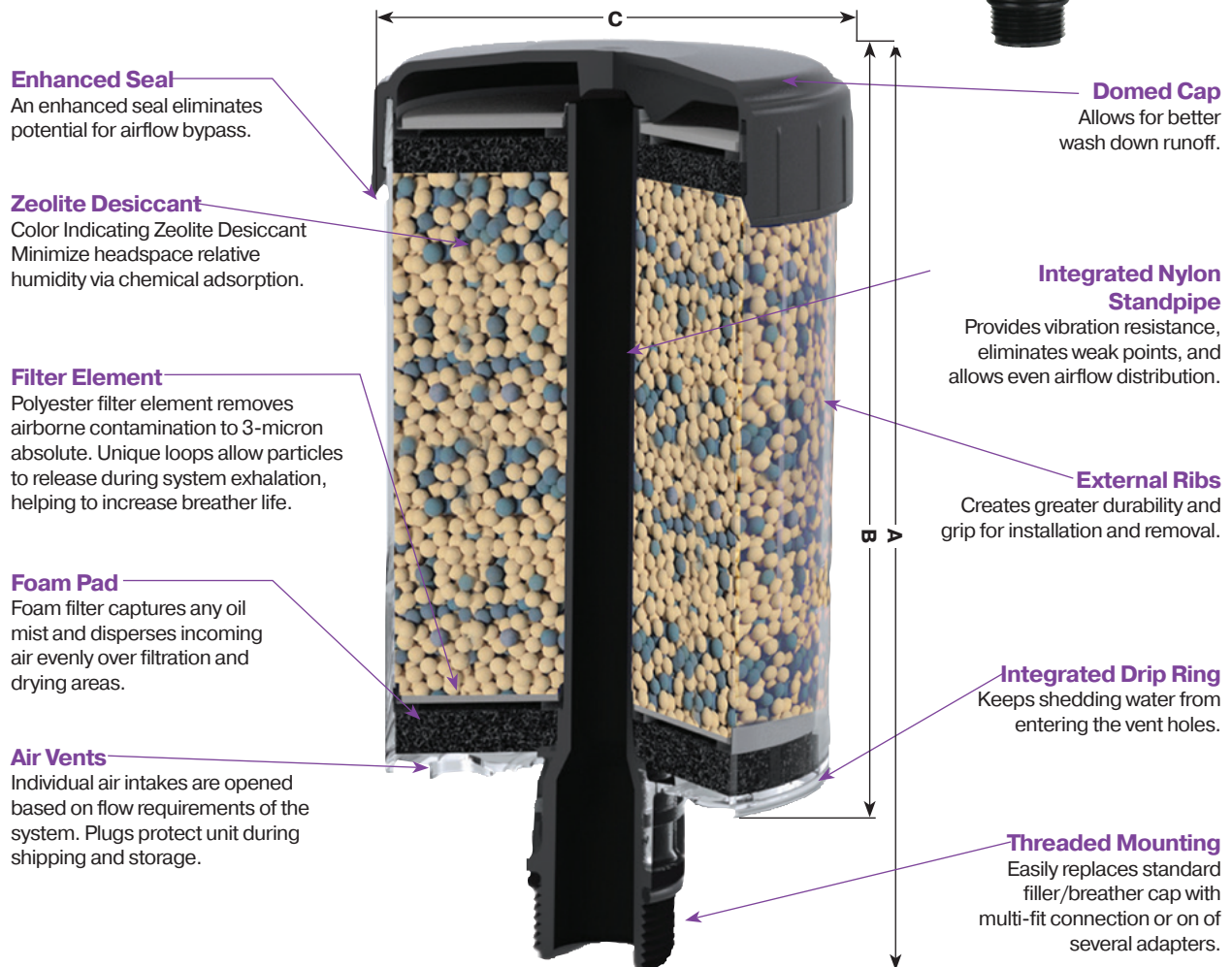

Part Number	A (in/mm)	B (in/mm)	C (in/mm)	Thread	Qty
934330	6.00/152	5.33/135	4.10/104	1" multi-fit male thread with o-ring seal compatible with 1" NPT; 1" NPSM; 1" BSPT; 1" BSPP	6 pcs
934331	8.00/203	7.33/186	4.10/104	1" multi-fit male thread with o-ring seal compatible with 1" NPT; 1" NPSM; 1" BSPT; 1" BSPP	6 pcs
934332	10.00/254	9.33/237	4.10/104	1" multi-fit male thread with o-ring seal compatible with 1" NPT; 1" NPSM; 1" BSPT; 1" BSPP	6 pcs

E Z Dri

Specifications

General Data	934330	934331	934332
Amount of ZEOLITE	0.83 lbs	1.33 lbs	1.81 lbs
	.376 kg	.603 kg	0.82 kg
Adsorption Capacity	84 ml	157 ml	209 ml
	2.8 fl oz	5 fl oz	7.1 fl oz
Net Weight of Unit	0.5 kg	0.8 kg	1.1 kg
	1.2 lbs	1.8 lbs	2.5 lbs
Filtration Area	8.4 in ² / 54.2 cm ²	8.4 in ² / 54.2 cm ²	8.4 in ² / 54.2 cm ²
Direction of Flow	Bidirectional	Bidirectional	Bidirectional
Operating Temp Range	-40°F to 302°F / -40°C to 150°C	-40°F to 302°F / -40°C to 150°C	-40°F to 302°F / -40°C to 150°C
Maximum Air Flow Rate	15 SCFM	15 SCFM	15 SCFM

Air Flow Performance

The curves below show the air flow performance of the E Z Dri breathers. To ensure the longest life possible, the initial clean pressure drop should not exceed 1.0 psid (.07 bar).

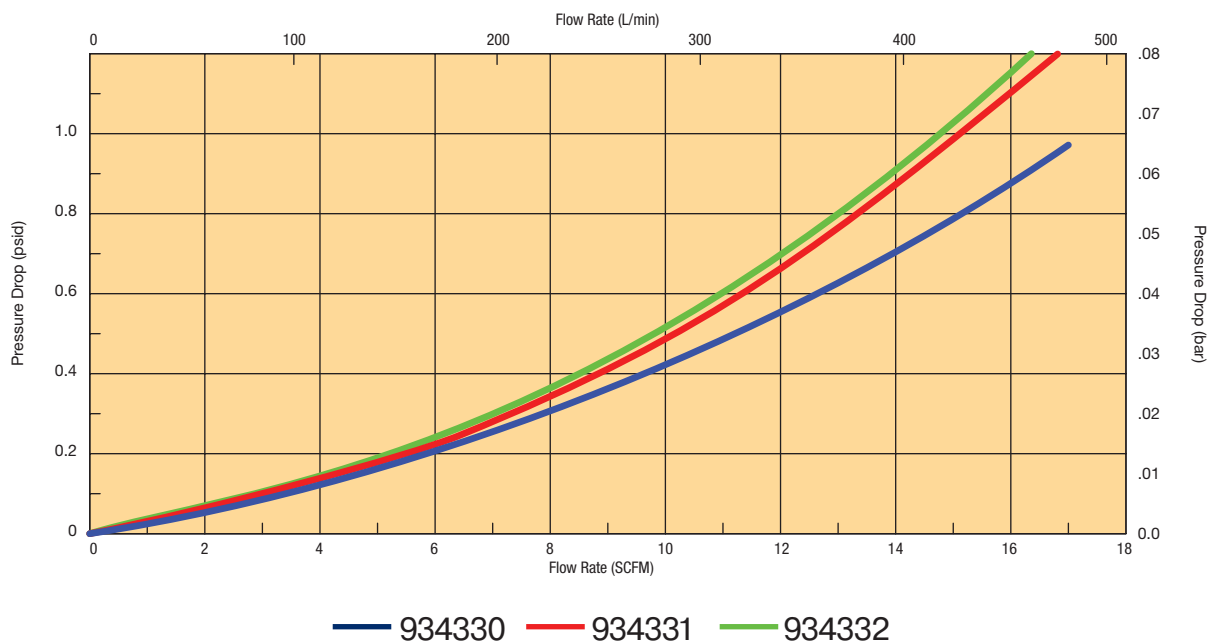

TriCeptor

Features

Materials:

Housing: Polycarbonate, Nylon 6/6 30% Glass Filled, Polypropylene

Filter Efficiency: 3 μ absolute ($\beta_3 \geq 200$)

Operating Temperatures: -20°F (-29°C) to 200°F (93°C)

Seals: Nitrile, PVC

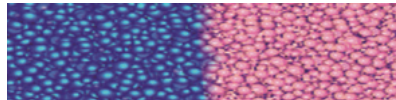

Active

Replace

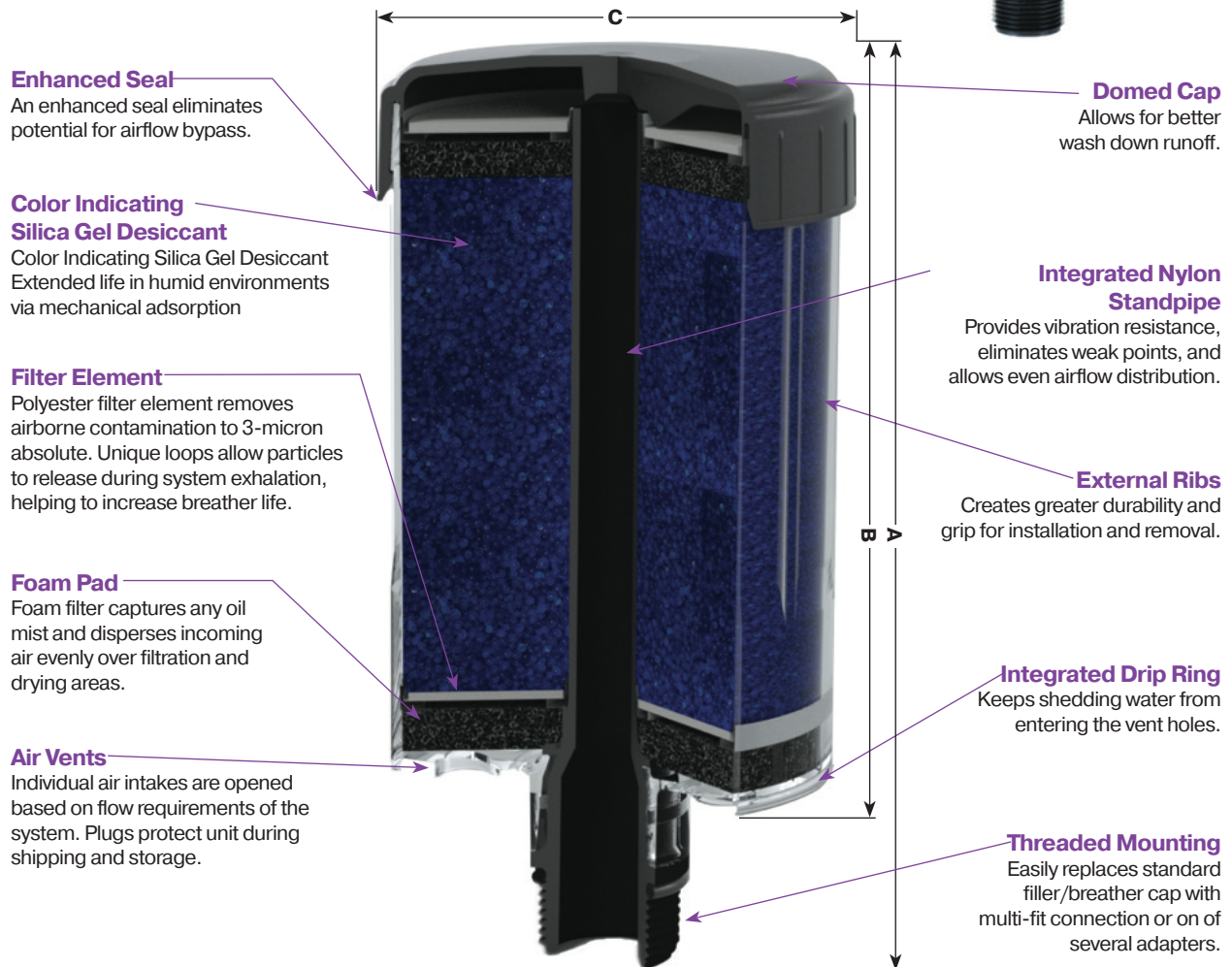

Part Number	A (in/mm)	B (in/mm)	C (in/mm)	Thread	Qty
934330T	6.00/152	5.33/135	4.10/104	1" multi-fit male thread with o-ring seal compatible with 1" NPT; 1" NPSM; 1" BSPT; 1" BSPP	6 pcs
934331T	8.00/203	7.33/186	4.10/104	1" multi-fit male thread with o-ring seal compatible with 1" NPT; 1" NPSM; 1" BSPT; 1" BSPP	6 pcs
934332T	10.00/254	9.33/237	4.10/104	1" multi-fit male thread with o-ring seal compatible with 1" NPT; 1" NPSM; 1" BSPT; 1" BSPP	6 pcs

TriCeptor

Specifications

General Data	934330T	934331T	934332T
Amount of Silica Gel	0.8 lbs	1.4 lbs	2.0 lbs
	0.4 kg	0.6 kg	0.9 kg
Adsorption Capacity	4.9 fl oz	8.7 fl oz	12.4 fl oz
	146 ml	257 ml	365 ml
Net Weight of Unit	1.2 lbs	1.9 lbs	2.6 lbs
	0.5 kg	0.9 kg	1.2 kg
Direction of Flow	Bidirectional	Bidirectional	Bidirectional
Operating Temp Range	-20°F to 200°F / -29°C to 93°C	-20°F to 200°F / -29°C to 93°C	-20°F to 200°F / -29°C to 93°C
Maximum Air Flow Rate	16 SCFM	16 SCFM	16 SCFM

Air Flow Performance

The curves below show the air flow performance of the TriCeptor breathers. To ensure the longest life possible, the initial clean pressure drop should not exceed 1.0 psid (.07 bar).

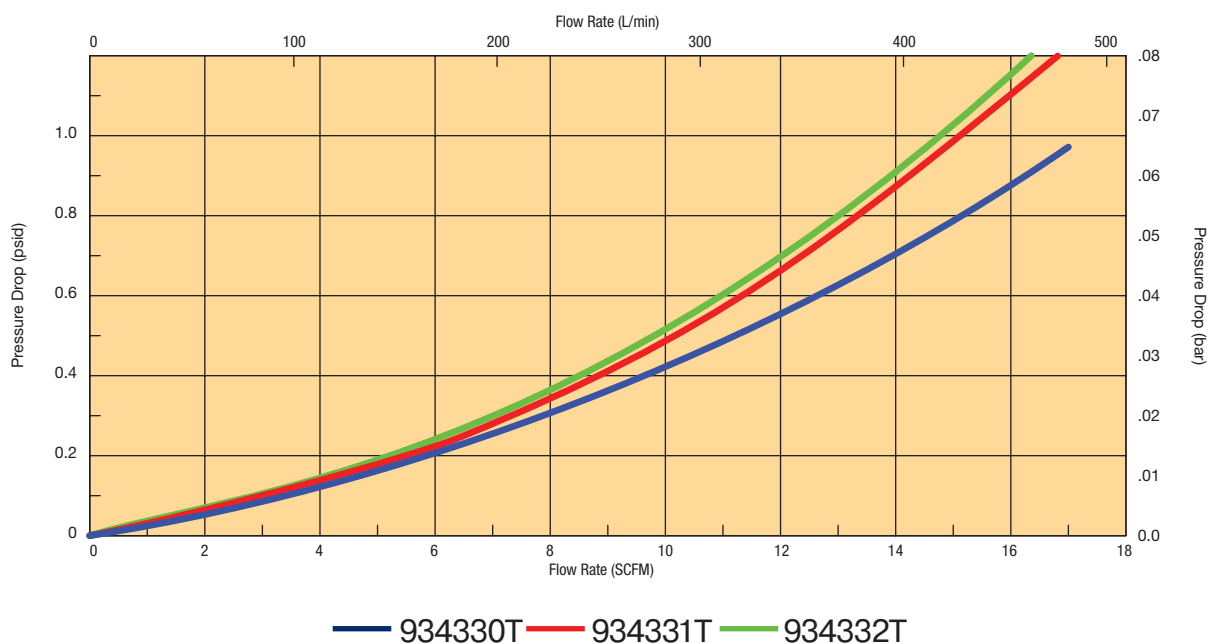

E Z Dri Mobile

Features and Specifications

Materials:

Casing: Polycarbonate/Polybutylene Terephthalate, Aluminum, Polyurethane, Polycarbonate
Stand pipe: Polycarbonate tube

Multi-layer Filtration: Foam pad filter, 3µ polyester filter, 0.3µ PTFE filter,
Operating Temperatures: -40°F (-40°C) to 300°F (149°C)

Seals: None



Active Replace

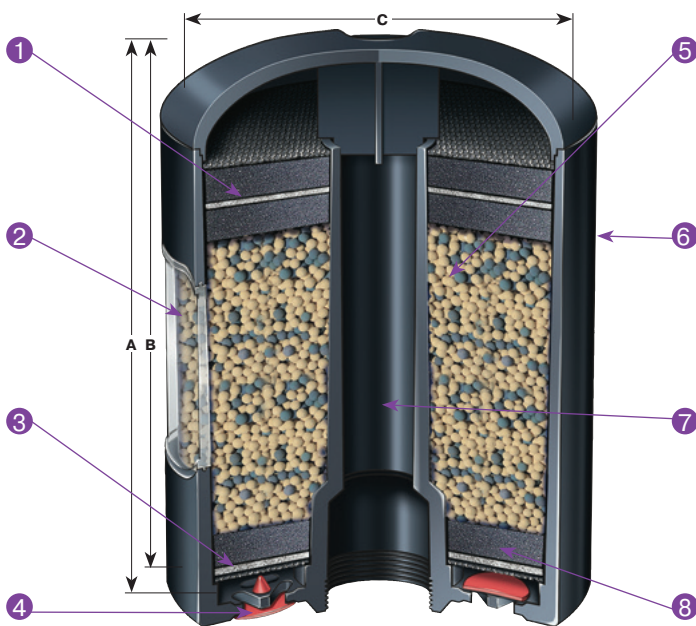

- 1 **Filter Element** - Second particulate filter element protects against migration of desiccant.
- 2 **Visual Indicator** - Windows on two sides of breather allow for easy monitoring of desiccant.
- 3 **Filter Element** - ePTFE filter removes airborne contamination to 0.3 absolute.
- 4 **Quad Check Valves** - Check-valves provide system pressurization, protecting system integrity and extending product life.
- 5 **Water Vapor Adsorbent** - Color-indicating zeolite adsorbs water from incoming air.
- 6 **Rugged Housing** - PC/PBT allow maximizes chemical compatibility at the surface and impact resistance at the core.
- 7 **Integrated Standpipe** - Resilient construction provides durability and allows oil mist to coalesce and drain back into the reservoir.
- 8 **Foam Pad** - Foam filter captures any oil mist and disperses incoming air evenly over filtration and drying areas.



941655

General Data

Amount of Desiccant	1.59 lbs / 0.72 kg
Adsorption Capacity	6.1 fl oz / 176 ml
Net Weight of Unit	3.2 lbs / 1.5 kg
Direction of Flow	Bidirectional
Operating Temperature Range	-40°F to 300°F / -40°C to 150°C
Maximum Flow Rate	15 SCFM

Unit Material Data

Material	Nylon and MXD6
Maximum Operating Temperature	300°F/149°C
Melting Point	320°F/160°C
Check Valve Adapter	Zinc Plated Steel

Filter Media

Material	EPTFE
Porosity	3.5-7.5 ft/min @ 0.5 in - H ₂ O (ASTM D 373)
Filtration Efficiency	Beta 200 @ 0.3µ (IES-RP-CCo21.1)

General Data

Apparent Bulk Density	700-800 kg/m ³
Average Particle Diameter	0.145"/3.68 mm
Specific Heat	0.25 BTU/lb F
Nominal Mesh Range	4x8
Average Crush Strength	35 lbs/15.9 kg

Part Number	A (in/mm)	B (in/mm)	C (in/mm)	Thread	Qty*
941655	6.34/158.5	6.17/156.7	5.1/129.5	1 1/2" - 16 UN Female Thread	1 pc

* Must be ordered in multiples of six (6).

TriCeptor Mobile

Features and Specifications

Materials:

Casing: Polycarbonate/Polybutylene Terephthalate, Aluminum, Polyurethane, Polycarbonate
Stand pipe: Polycarbonate tube

Multi-layer Filtration: Foam pad filter, 3μ polyester filter, 0.3μ PTFE filter,
Operating Temperatures: -40°F (-40°C) to 300°F (149°C)

Seals: None



941655T



Active Replace

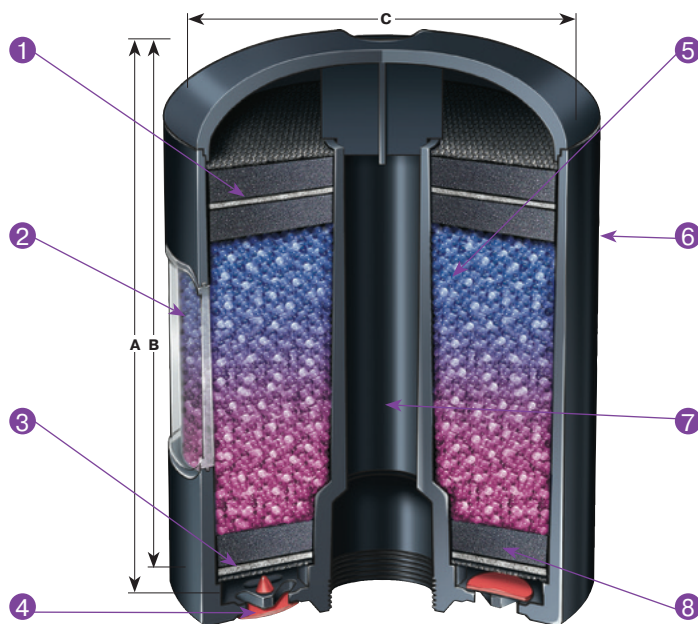

- 1 **Filter Element** - Second particulate filter element protects against migration of desiccant.
- 2 **Visual Indicator** - Windows on two sides of breather allow for easy monitoring of desiccant.
- 3 **Filter Element** - ePTFE filter removes airborne contamination to 0.3 absolute.
- 4 **Quad Check Valves** - Check-valves provide system pressurization, protecting system integrity and extending product life.
- 5 **Water Vapor Adsorbent** - Color-indicating silica gel adsorbs water from incoming air.
- 6 **Rugged Housing** - PC/PBT allow maximizes chemical compatibility at the surface and impact resistance at the core.
- 7 **Integrated Standpipe** - Resilient construction provides durability and allows oil mist to coalesce and drain back into the reservoir.
- 8 **Foam Pad** - Foam filter captures any oil mist and disperses incoming air evenly over filtration and drying areas.

General Data

Amount of Desiccant	1.75 lbs / 0.79 kg
Adsorption Capacity	10.7 fl oz / 315 ml
Net Weight of Unit	3.3 lbs / 1.5 kg
Direction of Flow	Bidirectional
Operating Temperature Range	-40°F to 300°F/ -40°C to 150°C
Maximum Flow Rate	16 SCFM

Unit Material Data

Material	Nylon and MXD6
Maximum Operating Temperature	300°F/148.9°C
Melting Point	320°F/160°C
Check Valve Adapter	Zinc Plated Steel

Filter Media

Material	EPTFE
Porosity	3.5-7.5 ft/min @ 0.5 in - H ₂ O (ASTM D 373)
Filtration Efficiency	Beta 200 @ 0.3μ (IES-RP-CCo21.1)

General Data

Apparent Bulk Density	700-800 kg/m3
Average Particle Diameter	0.145"/3.68 mm
Specific Heat	0.25 BTU/lb F
Nominal Mesh Range	8x12
Average Crush Strength	35 lbs/15.9 kg

Part Number	A (in/mm)	B (in/mm)	C (in/mm)	Thread	Qty*
941655T	6.34/158.5	6.17/156.7	5.1/129.5	1 1/2" - 16 UN Female Thread	1 pc

* Must be ordered in multiples of six (6).

TriCeptor Plus

Features

Materials:

Housing: Polycarbonate, Nylon 6/6 30% Glass Filled, Polypropylene

Filter Efficiency: 3 μ absolute ($\beta_3 \geq 200$)

Operating Temperatures: -20°F (-29°C) to 200°F (93°C)

Seals: Nitrile, PVC

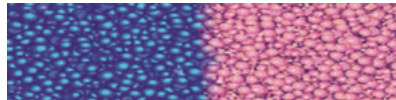

Active

Replace

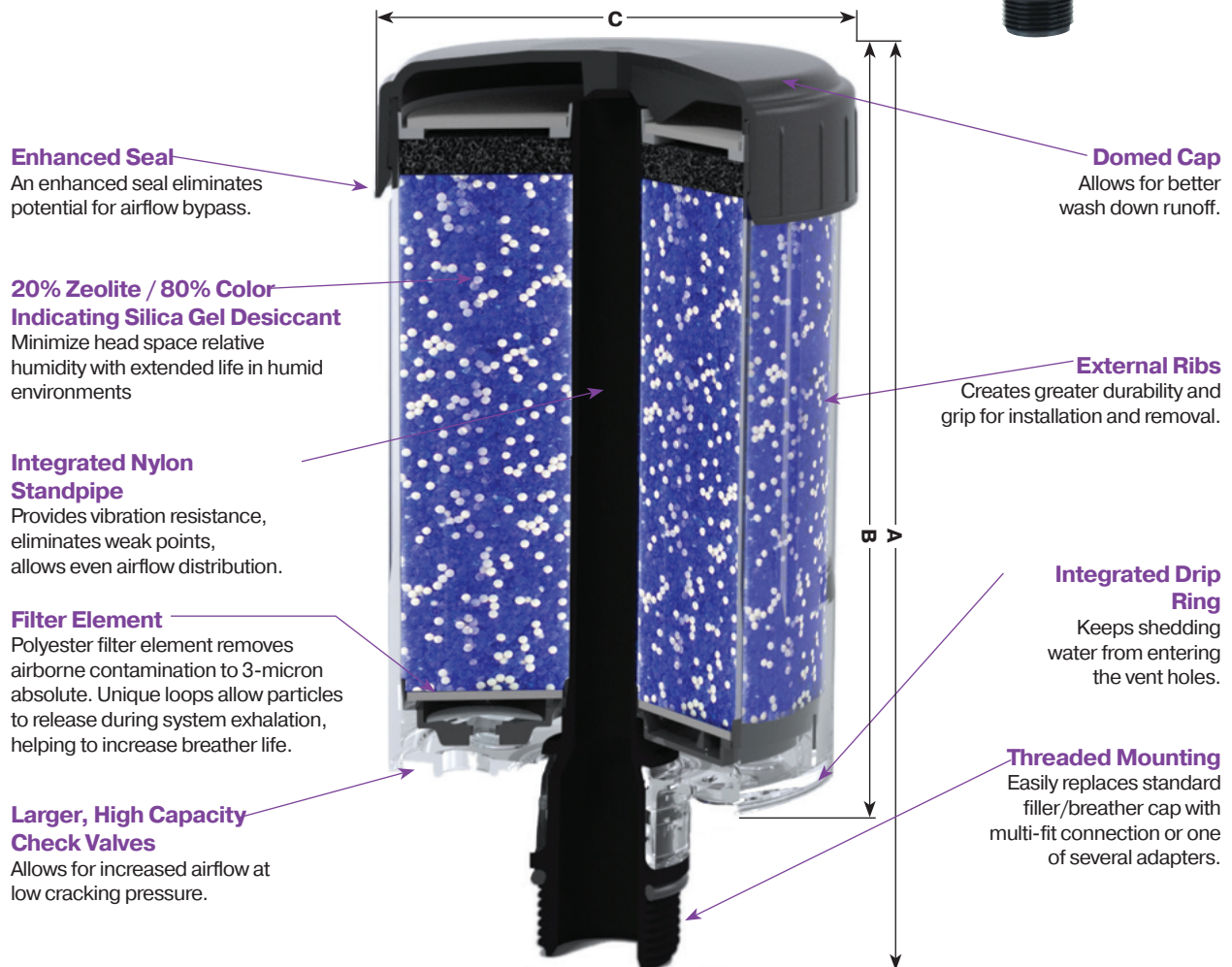

Part Number	A (in/mm)	B (in/mm)	C (in/mm)	Thread	Qty
947333	6.00/152	5.33/135	4.10/104	1" multi-fit male thread with o-ring seal compatible with 1" NPT; 1" NPSM; 1" BSPT; 1" BSPP	6 pcs
947334	8.00/203	7.33/186	4.10/104	1" multi-fit male thread with o-ring seal compatible with 1" NPT; 1" NPSM; 1" BSPT; 1" BSPP	6 pcs
947335	10.00/254	9.33/237	4.10/104	1" multi-fit male thread with o-ring seal compatible with 1" NPT; 1" NPSM; 1" BSPT; 1" BSPP	6 pcs

TriCeptor Plus

Specifications

General Data	947333	947334	947335
Amount of ZEOLITE	0.16 lbs	0.28 lbs	0.40 lbs
	0.07 kg	0.13 kg	0.18 kg
Amount of Silica Gel	0.64 lbs	1.12 lbs	1.60 lbs
	0.29 kg	0.51 kg	0.73 kg
Adsorption Capacity	4.7 fl oz	8.3 fl oz	11.8 fl oz
	139 ml	246 ml	349 ml
Net Weight of Unit	1.2 lbs	1.9 lbs	2.6 lbs
	0.54 kg	0.86 kg	1.18 kg
Direction of Flow	Bidirectional	Bidirectional	Bidirectional
Operating Temp Range	-20°F to 200°F / -29°C to 93°C	-20°F to 200°F / -29°C to 93°C	-20°F to 200°F / -29°C to 93°C
Maximum Flow Rate	12 SCFM	11 SCFM	10 SCFM

Air Flow Performance

The curves below show the air flow performance of the TriCeptor Plus breathers. To ensure the longest life possible, the initial clean pressure drop should not exceed 1.0 psid (.07 bar).

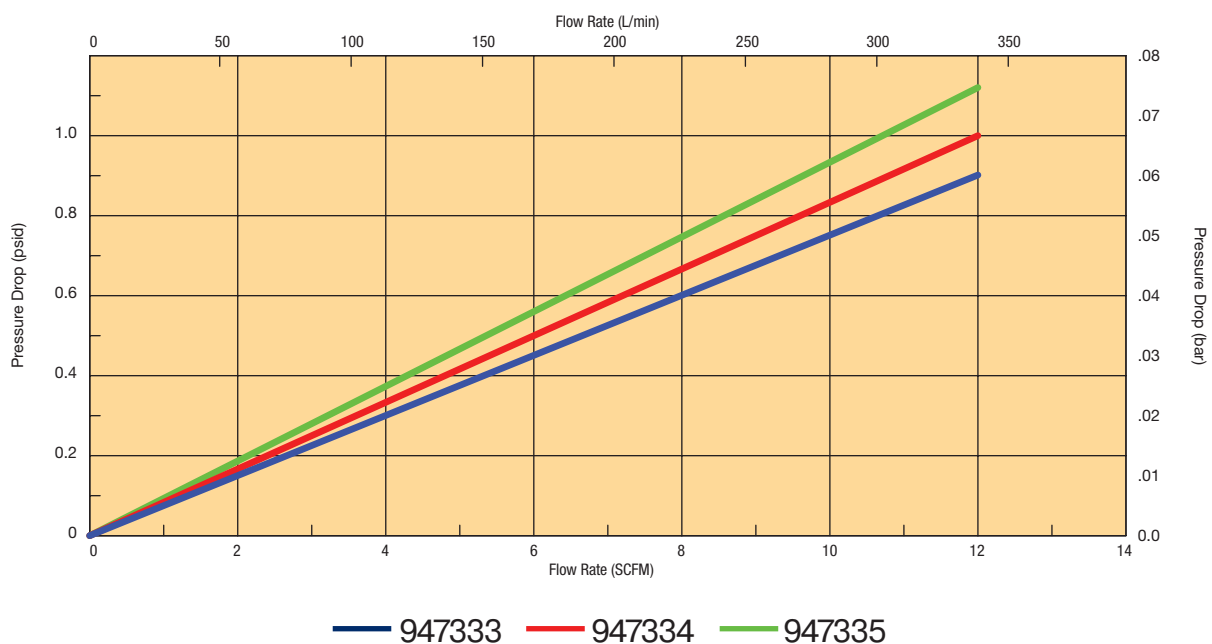

TriCeptor *Extended*

Features

Materials:

Housing: Polycarbonate, Nylon 6/6 30% Glass Filled, Polypropylene

Filter Efficiency: 3μ absolute ($\beta_3 \geq 200$)

Operating Temperatures: -20°F (-29°C) to 200°F (93°C)

Seals: Nitrile, PVC

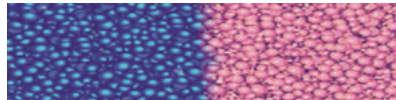

Active Replace

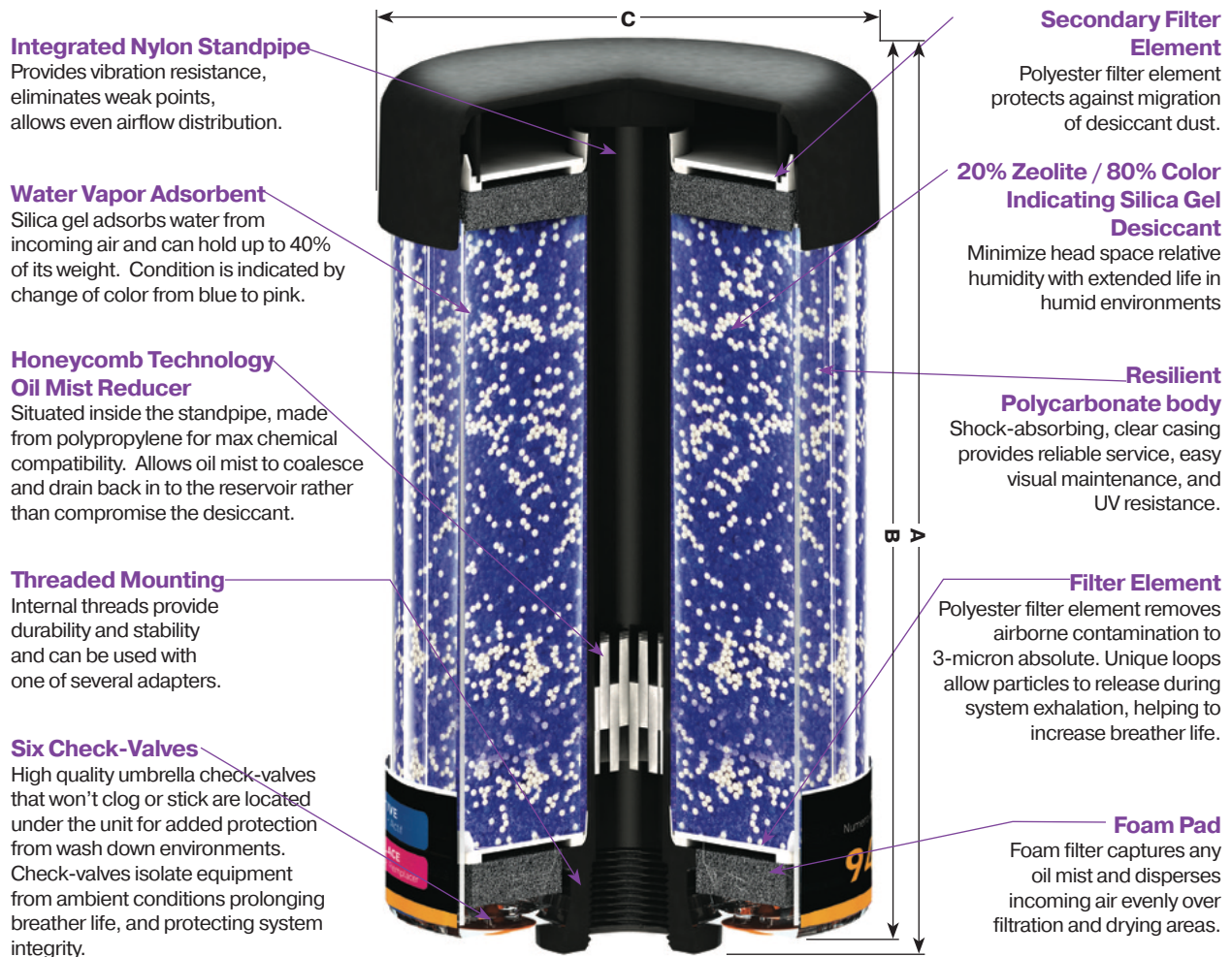

Part Number	A (in/mm)	B (in/mm)	C (in/mm)	Thread	Qty
947336	6.40/163	6.02/153.34	5.66/143.88	1" Female (FNPT)	6 pcs
947337	8.20/208	7.82/198.34	5.66/143.88	1" Female (FNPT)	6 pcs
947338	10.00/254	9.62/244.34	5.66/143.88	1" Female (FNPT)	6 pcs

TriCeptor *Extended*

Specifications

General Data	947336	947337	947338
Amount of ZEOLITE	0.42 lbs	0.64 lbs	0.84 lbs
	0.19 kg	0.29 kg	0.38 kg
Amount of Silica Gel	1.68 lbs	2.56 lbs	3.35 lbs
	0.76 kg	1.16 kg	1.52 kg
Adsorption Capacity	12.8 fl oz	18.9 fl oz	25.0 fl oz
	379 ml	558 ml	738 ml
Net Weight of Unit	3.5 lbs	4.8 lbs	5.9 lbs
	1.59 kg	2.18 kg	2.68 kg
Direction of Flow	Bidirectional	Bidirectional	Bidirectional
Operating Temp Range	-20°F to 200°F / -29°C to 93°C	-20°F to 200°F / -29°C to 93°C	-20°F to 200°F / -29°C to 93°C
Maximum Flow Rate	26 SCFM	25 SCFM	24 SCFM

Air Flow Performance

The curves below show the air flow performance of the TriCeptor *Extended* breathers. To ensure the longest life possible, the initial clean pressure drop should not exceed 1.0 psid (.07 bar).

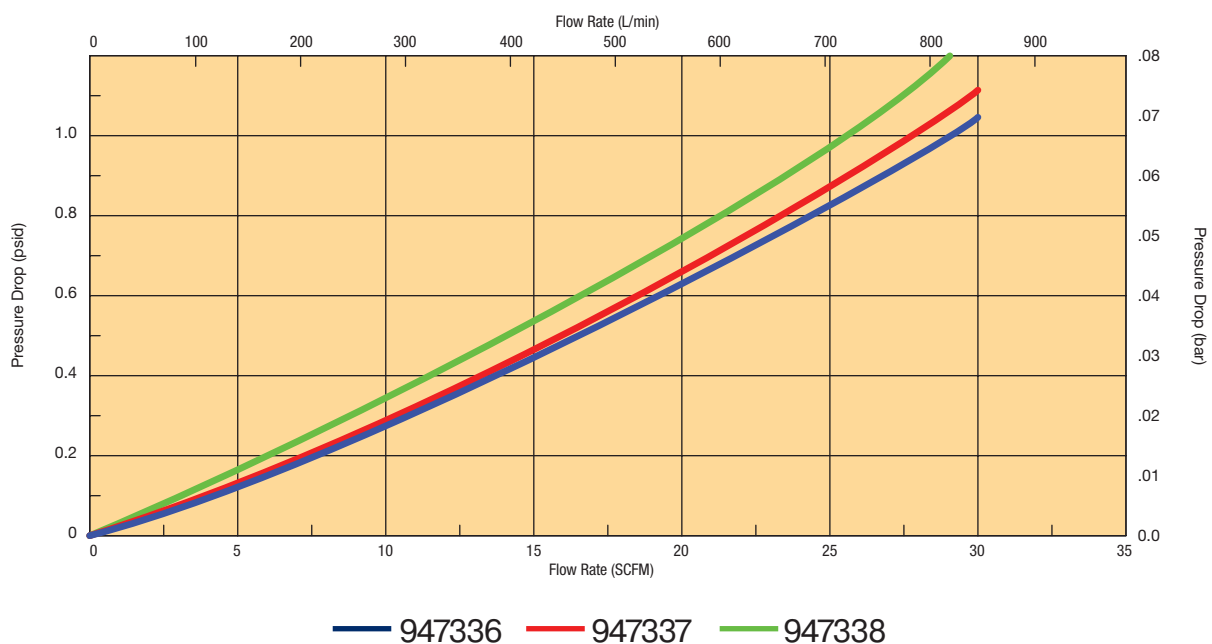

ClearConnect

Features

Materials:

Housing: Polycarbonate, Nylon 6/6 30% Glass Filled, Polypropylene

Filter Media: Polyurethane, polyester

Filter Efficiency: 3μ absolute ($\beta_3 \geq 200$)

Operating Temperatures: -20°F (-29°C) to 158°F (70°C)

Seals: Nitrile, PVC

Net Weight of Units:

947339 - 2.7 lbs (1.22 kg) CCS10SGBM8M1 - 2.8 lbs (1.27 kg)

947340 - 5.9 lbs (2.68 kg) CCE10SGBM8F1 - 6.0 lbs (2.72 kg)

Relative Humidity Sensor

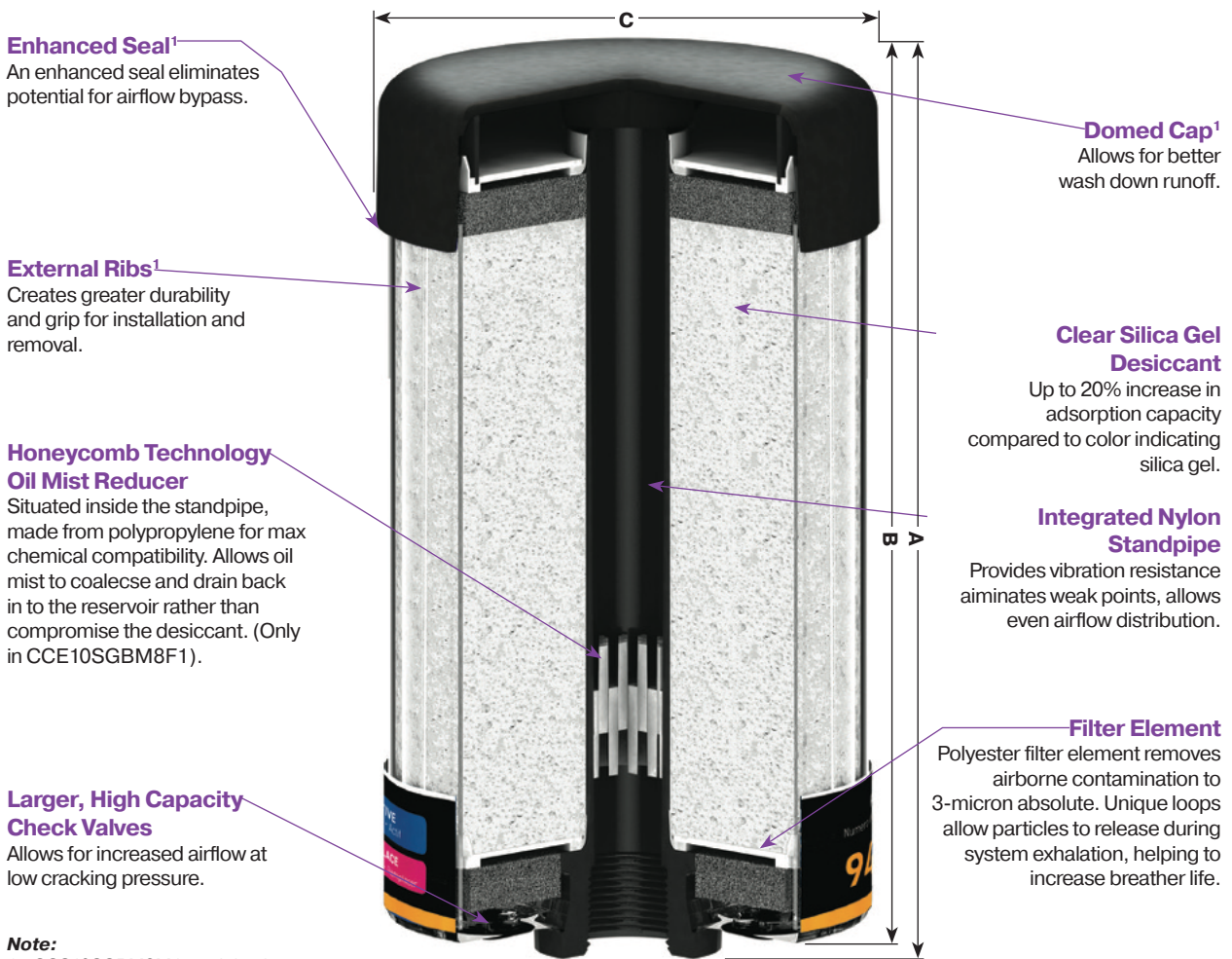

Note:

1 - CCS10SGBM8M1 model only

Breather with Sensor	A (in/mm)	B (in/mm)	C (in/mm)	Thread	Qty
CCS10SGBM8M1	10/253	9.3/237	4.1/104	1" multi-fit male thread with o-ring seal compatible with 1" NPT; 1" NPSM; 1" BSPT; 1" BSPP	1 pcs
CCE10SGBM8F1	10/253	9.6/243	5.7/144	1" Female (FNPT)	1 pcs
Replacement Breather					
947339	10/253	9.3/237	4.1/104	1" multi-fit male thread with o-ring seal compatible with 1" NPT; 1" NPSM; 1" BSPT; 1" BSPP	6 pcs
947340	10/253	9.6/243	5.7/144	1" Female (FNPT)	6 pcs

ClearConnect

Specifications



Materials & Components

Casing	Polycarbonate, Steel (ball plunger)
Cap	Thermoplastic elastomers (TPE), Steel (screws)
Circuit Board	LED lights, FR4 Fiberglass
M8 Connector	Polyamide 67 GF340, Silicone and Nickel Plated Copper Alloy

Power

Supply Voltage	9-28 V DC
Operational Current Rating	30 mA

Pin 1	Brown	9-28V DC
Pin 2	White	TXA (Low)
Pin 3	Black	TXB (High)
Pin 4	Blue	DC Reference
(Mark State)		

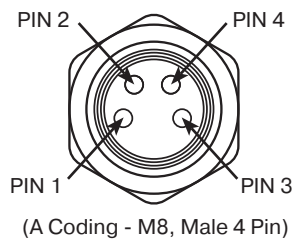

Environment

13.56 MHz RFID (Module & Sensor-board communication)
 Intended for indoor and outdoor use
 Altitude up to 16,404 ft (5,000 m)
 Maximum Relative Humidity: 100% at up to 158°F (70°C)
 Dustproof/Waterproof (IP66)
 Hazardous Ratings: Not rated for hazardous locations
 FCC, CE, Reach, RoHS

Connectivity/Data Output

A Coding - M8, 4 pin male
 RS485 Half Duplex (Modbus)

Data Storage

Data readings every 60 minutes
 Stores 365 Half days of hourly data points

Power/Data Cable

4 position connector with wire leads x 3m connected
 breather cable assembly (sold separately)

Air Flow Performance

The curves below show the air flow performance of the ClearConnect breathers. To ensure the longest life possible, the initial clean pressure drop should not exceed 1.0 psid (.07 bar).

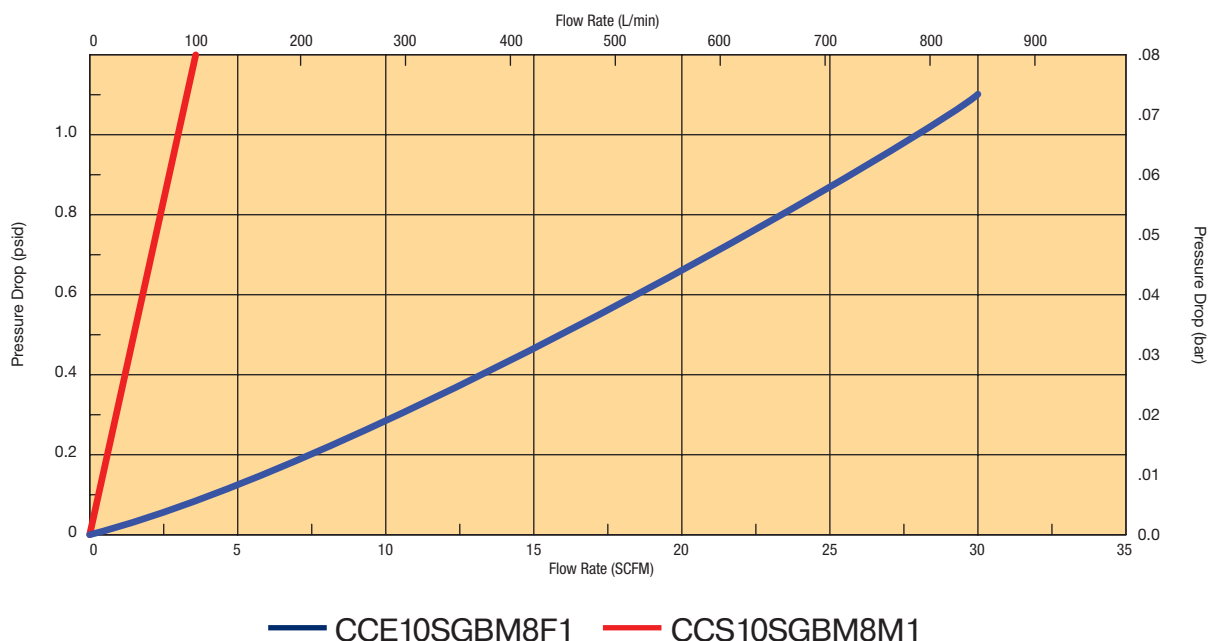

Desiccant Breathers

Accessories

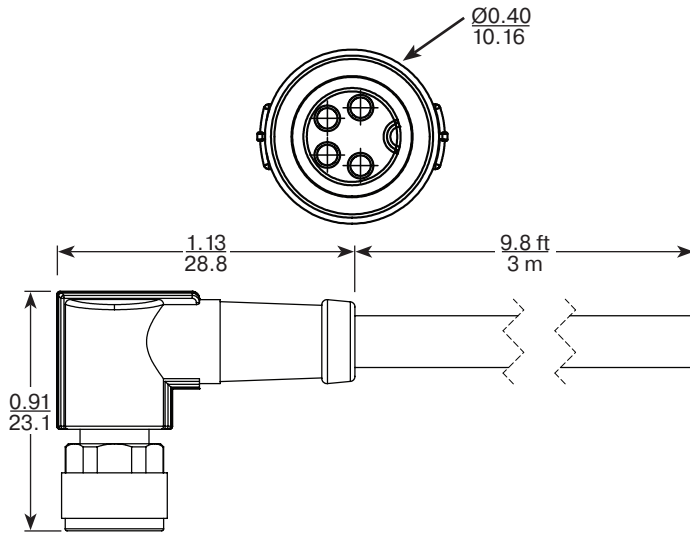

ClearConnect Power/Data Cable

Length: 3 Meters

Connection: A Coding - M8, 4 Pin

Recommended Torque: 0.4Nm

Temperature Range: 23°F to 176°F (-5°C to 80°C)

Part Number	Description	Qty
947341	Power/Data Cable	1 pc

For use with ClearConnect

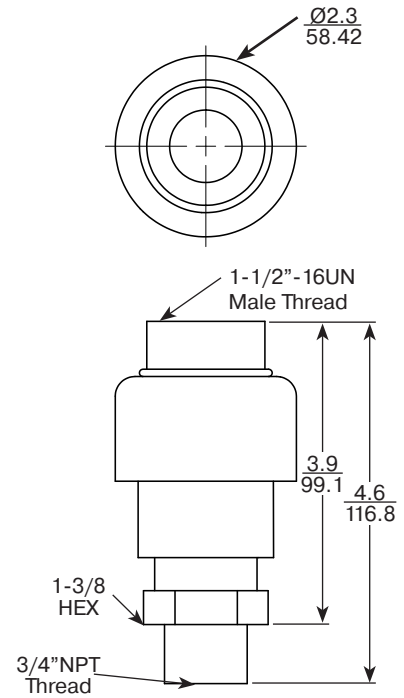

Part Number	Description	Qty
946056	Check Valve Adapter	1 pc

For use with Mobile Breathers

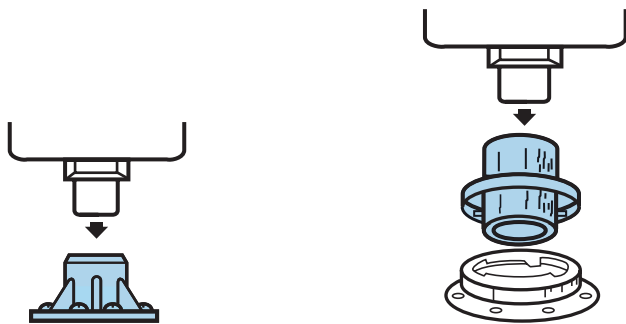

Part Number	Description	Qty
937546	Field Adapter	1 pc

For use with E Z Dri, Triceptor, Triceptor *Plus*, Triceptor *Extended* and ClearConnect

Part Number	Description	Qty
937463	Flange Adapter	1 pc

For use with E Z Dri, Triceptor, Triceptor *Plus*, Triceptor *Extended* and ClearConnect

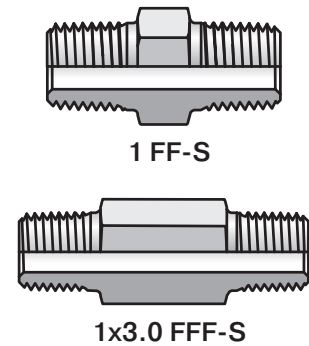

Part Number	Description	Qty
1 FF-S	2.34" Pipe with 1" NPT connections	1 pc
1x3.0 FFF-S	3" Pipe with 1" NPT connections	1 pc

Please contact Parker Tube Fittings Division at tfd.support@support.com or call 614.279.7070

inches
mm

Drawings are for reference only.
Contact factory for current version.

Desiccant Breathers

Maintenance

	Installation	Disposal
E Z Dri <i>Zeolite Breather</i>	<ol style="list-style-type: none"> 1. Remove safety cap from bottom of standpipe 2. Remove caps from bottom vent holes 3. Mount breather to the tank or reservoir using the adapter best suited for the application 	<ol style="list-style-type: none"> 1. Verify the breather is fully saturated - all blue beads will be beige in color 2. Remove breather from gearbox, tank, reservoir, or other application 3. Remove and save the adapter fitting to be used with a new breather 4. Verify and dispose of breather in accordance with your state and local environmental control regulations
TriCeptor <i>Silica Gel Breather</i> TriCeptor Plus <i>Mixed Desiccant Breather</i>	<ol style="list-style-type: none"> 1. Remove safety cap from bottom of standpipe 2. Remove caps from bottom vent holes 3. Mount breather to the tank or reservoir using the adapter best suited for the application 	<ol style="list-style-type: none"> 1. Verify the breather is fully saturated - all blue beads will be pink in color 2. Remove breather from gearbox, tank, reservoir, or other application 3. Remove and save the adapter fitting to be used with a new breather 4. Verify and dispose of breather in accordance with your state and local environmental control regulations
Mobile <i>Rugged Breather</i>	<ol style="list-style-type: none"> 1. Remove safety cap from bottom of standpipe 2. Mount breather to the tank or reservoir using the adapter best suited for the application 	<ol style="list-style-type: none"> 1. Verify the breather is fully saturated 2. Remove breather from gearbox, tank, reservoir, or other application 3. Remove and save the adapter fitting to be used with a new breather 4. Verify and dispose of breather in accordance with your state and local environmental control regulations
TriCeptor Extended <i>Mixed Desiccant Breather</i>	<ol style="list-style-type: none"> 1. Remove safety cap from bottom of breather 2. Mount breather to the tank or reservoir using the adapter best suited for the application 	<ol style="list-style-type: none"> 1. Verify the breather is fully saturated - all blue beads will be pink in color 2. Remove breather from gearbox, tank, reservoir, or other application 3. Remove and save the adapter fitting to be used with a new breather 4. Verify and dispose of breather in accordance with your state and local environmental control regulations
ClearConnect <i>Wired Relative Humidity Sensor</i>	<ol style="list-style-type: none"> 1. Remove safety cap from bottom of breather 2. Connect sensor communication module using provided wiring diagram 3. Mount breather to the tank or reservoir using the adapter best suited for the application 4. Install wired sensor communication module onto breather body 	<ol style="list-style-type: none"> 1. Verify the breather is fully saturated - Change when breather life remaining is 0%. 2. Remove sensor communication module from spent breather cartridge - slide toward top cap. 3. Remove breather from gearbox, tank, reservoir, or other application 4. Remove and save the adapter fitting to be used with a new breather 5. Verify and dispose of breather in accordance with your state and local environmental control regulations



Hydraulic & Fuel Filtration Division
www.parker.com/emhff

Last updated August 4th, 2023

Parker's willingness to conduct business with Buyer is expressly conditioned on Buyer's assent to Parker's Offer of Sale. www.parker.com/saleterms