



50P Series

High Pressure Filters



ENGINEERING YOUR SUCCESS.

50P Series

Applications

Applications for 50P series filters

- Automotive specified equipment
- Hydrostatic transmission circuits
- Servo and proportional controls
- Offshore drilling rigs
- Mining equipment
- Power units

The design objective for all Parker filters is to achieve a sensible balance between cost and performance. We use state of the art technology to arrive at innovative yet practical designs, which are cost effective for OEM's and users alike.

The 50P series allows you to customize each filter to closely match your needs. Choose the options which best fit your application.

The 50P series filters are bowl-up, which provides several possible advantages. The bowl-up mounting makes servicing the elements quick and easy. Simply remove the top cover to access the element. A drain port is provided to allow oil removal prior to element servicing. This design reduces the possibility of oil spillage and injury to maintenance personnel.

The 50P series has optional manifold porting for space saving. The porting is also designed to match the installation of many other manufacturers. Most important, the 50P series meets the SAE HF4 automotive standard.

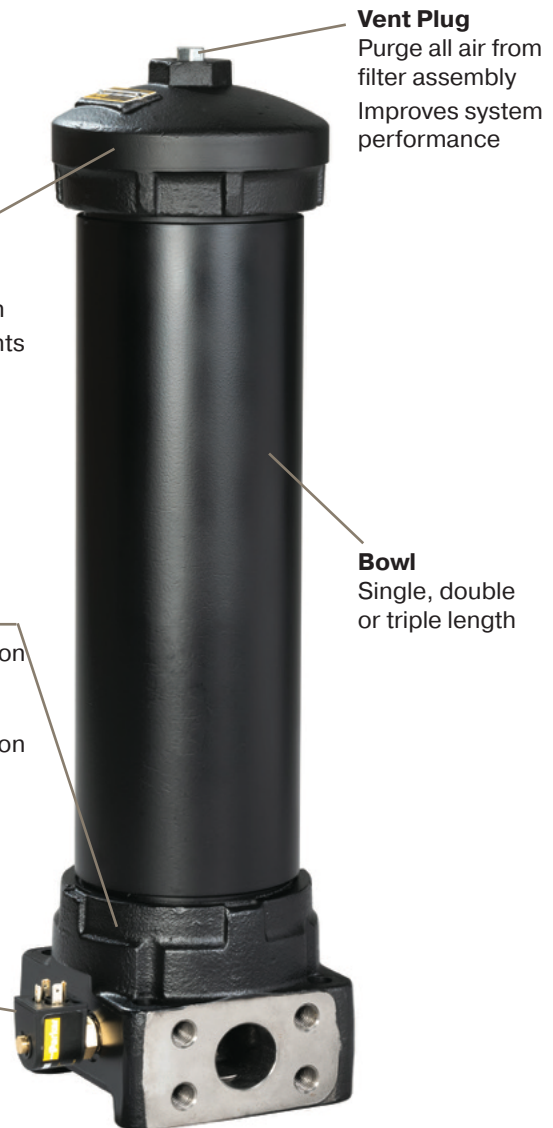

Vent Plug
Purge all air from filter assembly
Improves system performance

Cover
Durable ductile iron
Top service elements
No oil spills during service

Bowl
Single, double or triple length

Head
Ductile iron construction
SAE or manifold ports
Meets SAE HF4 automotive specification

Indicators
Visual, electrical or analog
Several connector options

Drain Plug (not visible)
Drain oil for easy service

Bypass (not visible)
Cartridge style
Precision matched assemblies

50P Series

Features

O-Ring Seal

Positive sealing for optimum element efficiency

Microglass Media

- Multi-layer for high capacity and high efficiency
- Multiple micron sizes available
- Wire reinforced to prevent pleat bunching

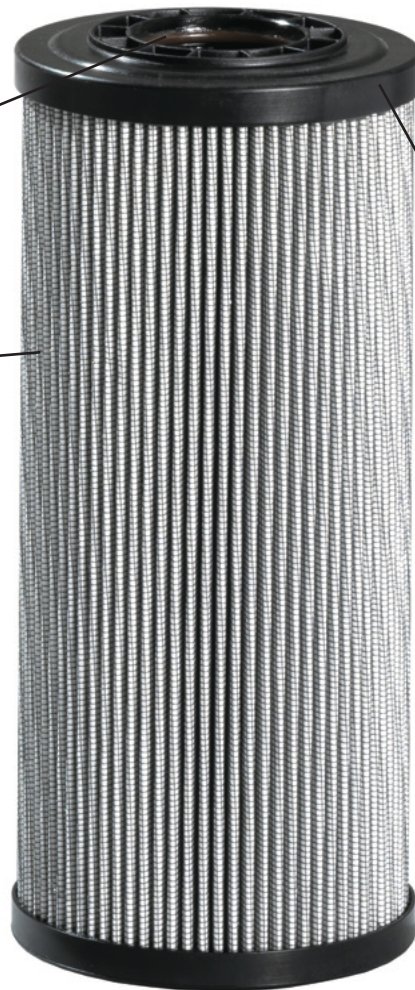

Plastic End Caps

- Excellent corrosion protection
- Laser marked for clear long lasting identification

Spiral Support Cylinders (Not visible)

- High strength consistent support
- Continuous length eliminates leak points and increases surface area
- Meets SAE HF4 specification for automotive uses

Feature	Advantage	Benefit
Base mounted filter	No brackets required for installation	Reduces installation costs
Top access cover	Removing the element from the top is lighter than removing entire bowl	Allows for easier element replacement
Visual, electrical and analog indicators	Know exactly when to service elements	Ensures maximum element life without entering bypass or replacing elements prematurely.
Drain port	Drain all oil from assembly prior to servicing	No oil mess
Vent port	Purges all trapped air in filter	Get the maximum performance from elements Prevents a "spongy" system
Multipass tested elements	Element performance backed by recognized test standards	Elements selected will have consistent performance levels
Microglass elements	Multi-layer media Wire reinforced pleats	High capacity with high efficiency No performance loss from pleat bunching

50P Series

50P-1 Element Performance

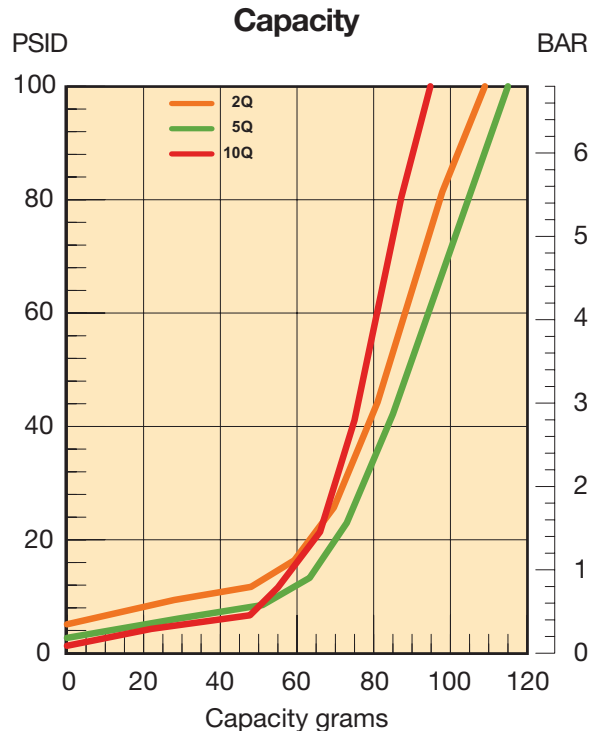
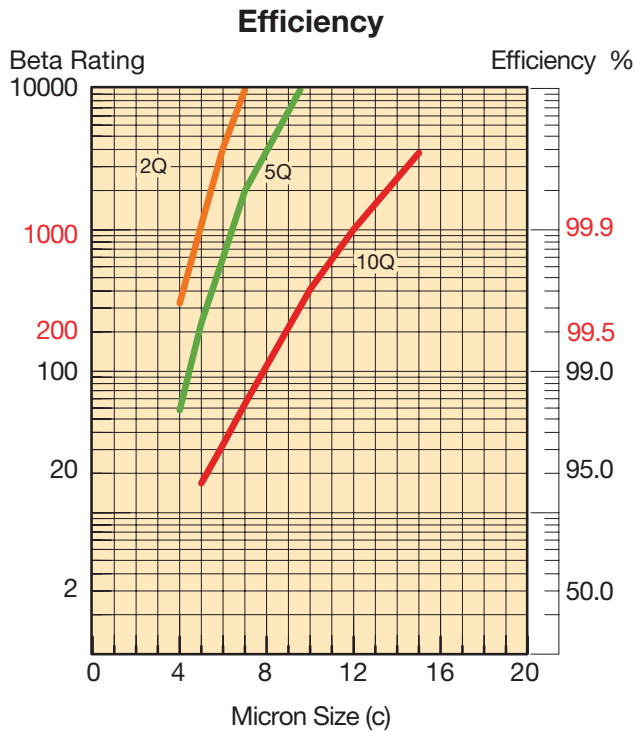

Results typical from Multi-pass tests run per test standard ISO 16889 @ 50 gpm to 100 psid terminal - 10 mg/L BUGL
Refer to Appendix for relationship to test standard ISO 4572.

*High Collapse Correction Factor:
QH Elements (2000 psid) = 1.4 times reported loss

Flow vs. Pressure Loss

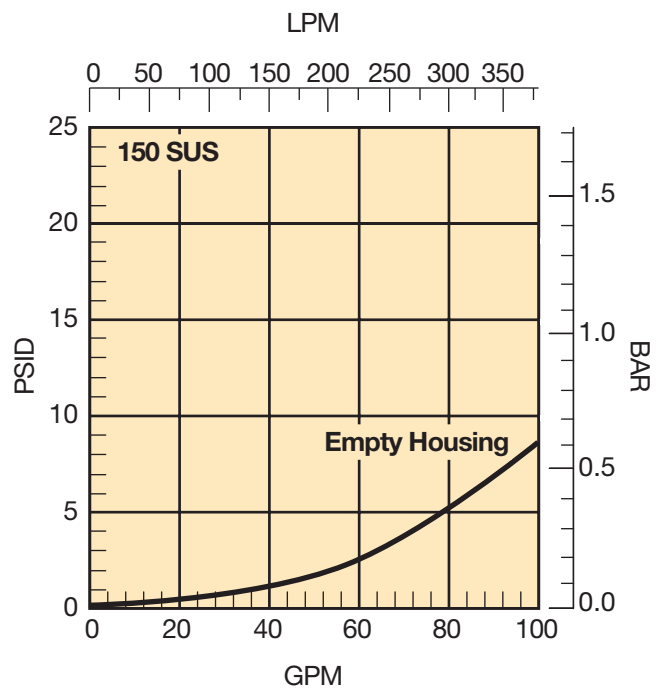
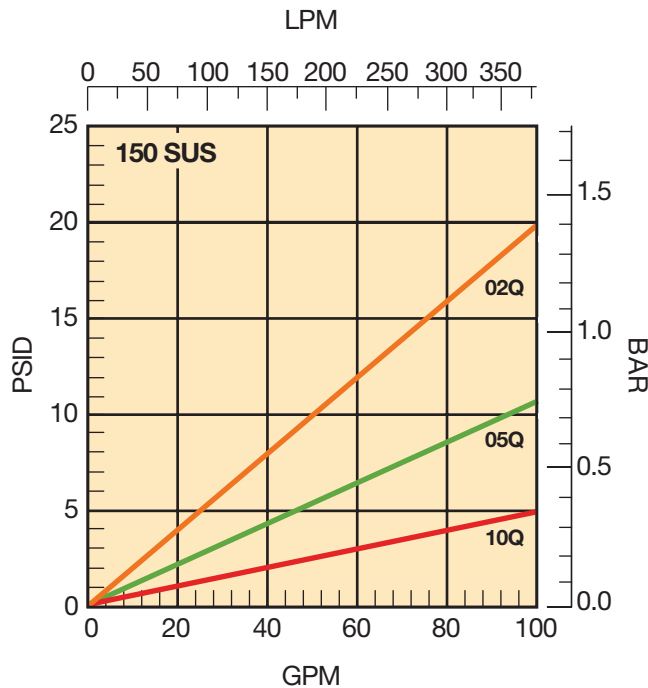

50P Series

50P-2 Element Performance

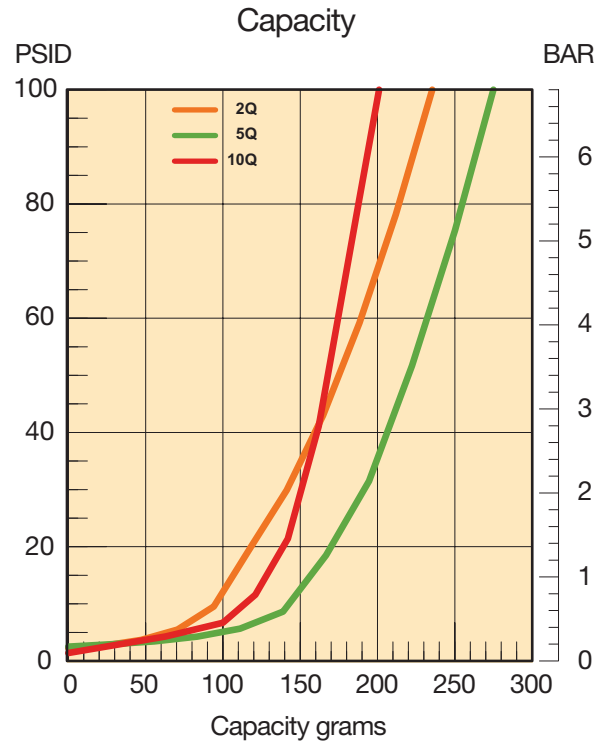
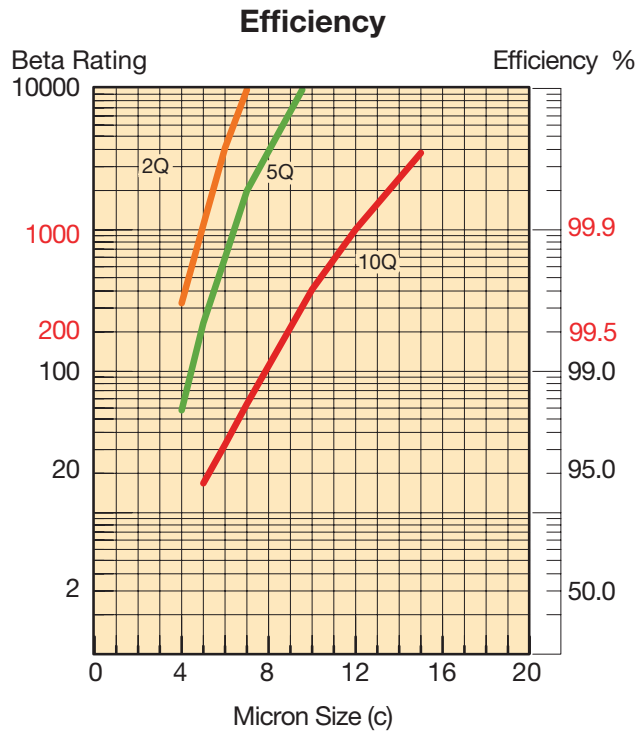

Results typical from Multi-pass tests run per test standard ISO 16889 @ 80 gpm to 100 psid terminal - 10 mg/L BUGL
Refer to Appendix for relationship to test standard ISO 4572.

Flow vs. Pressure Loss

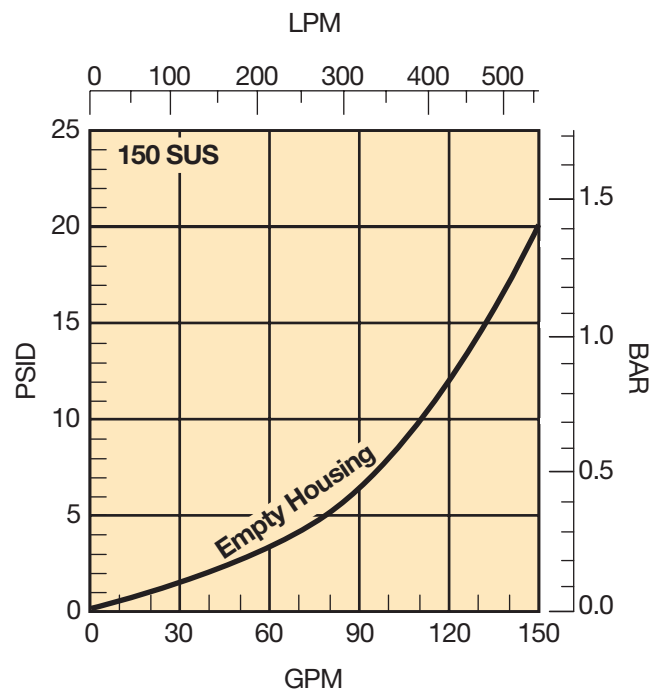
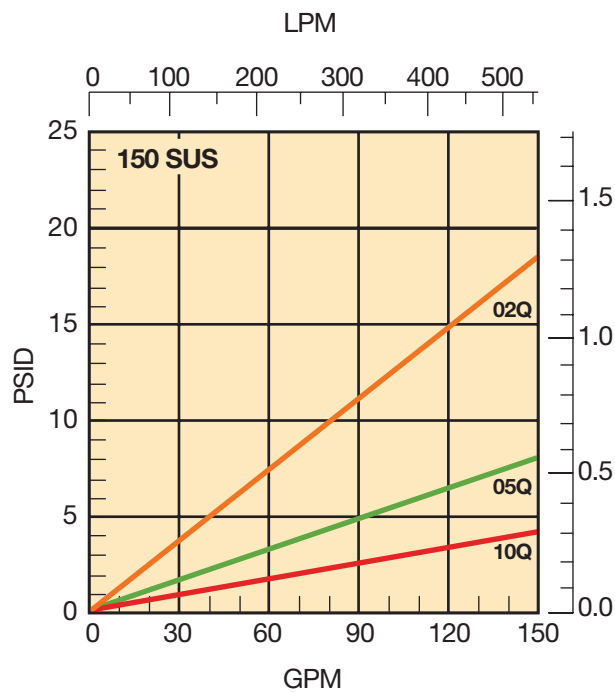

50P Series

50P-3 Element Performance

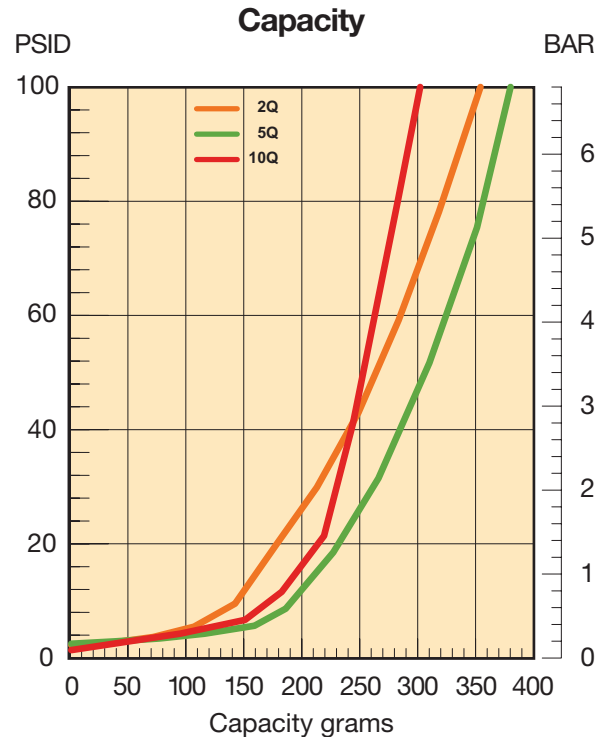
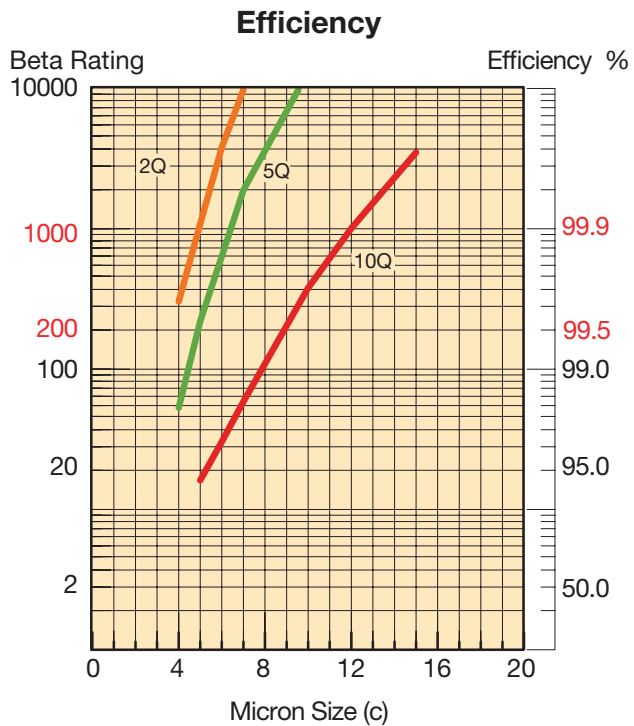

Results typical from Multi-pass tests run per test standard ISO 16889 @ 80 gpm to 100 psid terminal - 10 mg/L BUGL
 Refer to Appendix on pages 264-265 for relationship to test standard ISO 4572.

Flow vs. Pressure Loss

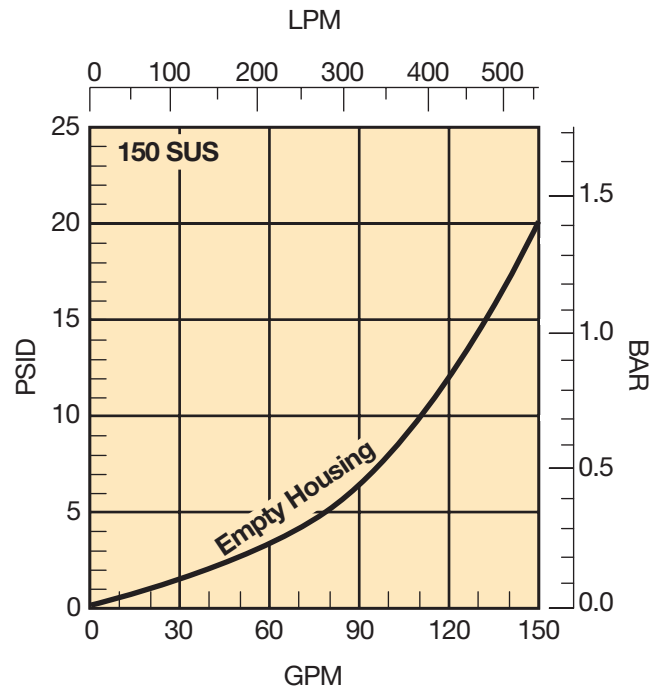
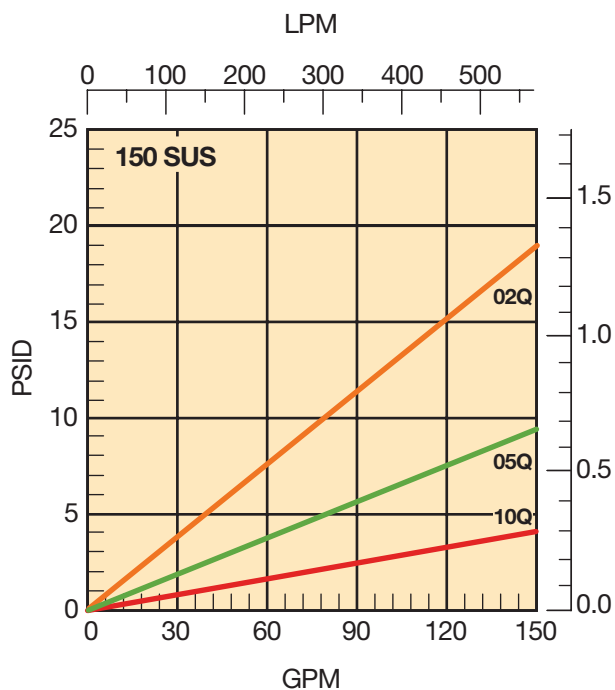

50P Series

Specifications

Pressure Ratings:

Maximum Allowable Operating Pressure (MAOP): 5000 psi (344.8 bar)
 Rated Fatigue Pressure: 3500 psi (241.4 bar)
 Design Safety Factor: 2.5:1

Element Collapse Rating:

150 psid (10.2 bar) standard

Operating Temperatures:

Buna: -40°F (-40°C) to 225°F (107°C)
 Fluorocarbon: -15°F (-26°C) to 275°F (135°C)

Filter Materials:

Head (base) and Cover: ductile iron
 Bowl: seamless steel tube

Shipping Weights (approximate):

50P-1: 56 lb. (25.4 kg)
 50P-2: 77 lb. (34.9 kg)
 50P-3: 95 lb. (43 kg)

Dimensions: mm/inches	50P-1	50P-2	50P-3
X	387.1 15.24	622.8 24.52	850.4 33.48
Z	254.0 10.00	508.0 20.00	760.2 30.00

Drawings are for reference only.
 Contact factory for current version.

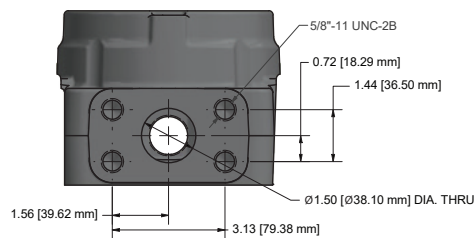

SAE 1 1/2" FLANGE FACE

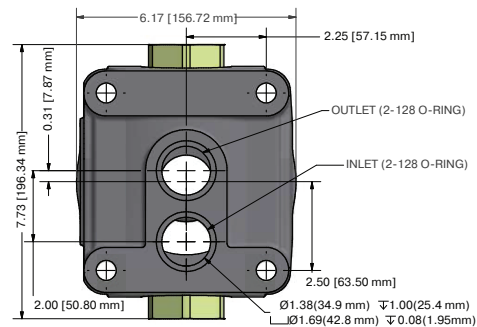

MANIFOLD PORTS ON
 BOTTOM OF HEAD

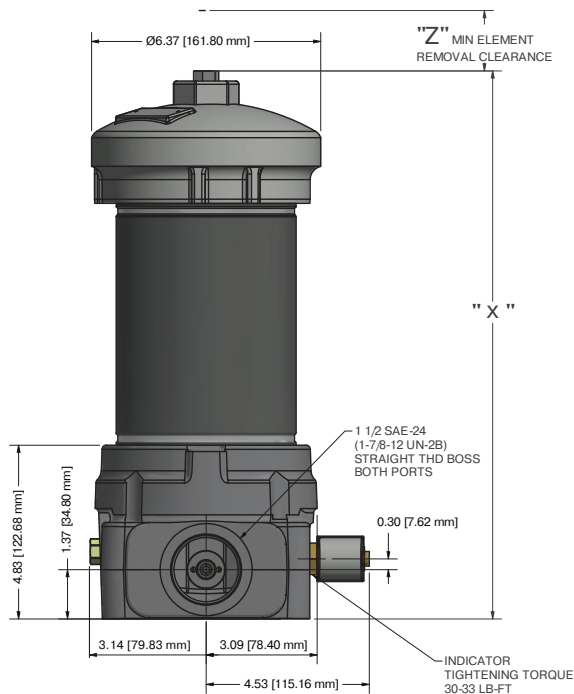

"Z" MIN ELEMENT
 REMOVAL CLEARANCE

"X"

1 1/2 SAE-24
 (1-7/8-12 UN-2B)
 STRAIGHT THD BOSS
 BOTH PORTS

0.30 [7.62 mm]

INDICATOR
 TIGHTENING TORQUE
 30-33 LB-FT

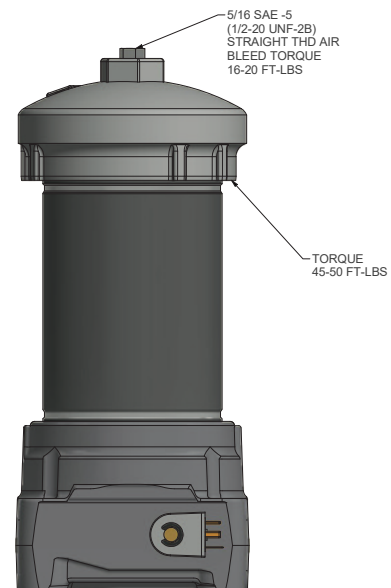

5/16 SAE -5
 (1/2-20 UNF-2B)
 STRAIGHT THD AIR
 BLEED TORQUE
 16-20 FT-LBS

TORQUE
 45-50 FT-LBS

50P Series

Indicator Specifications

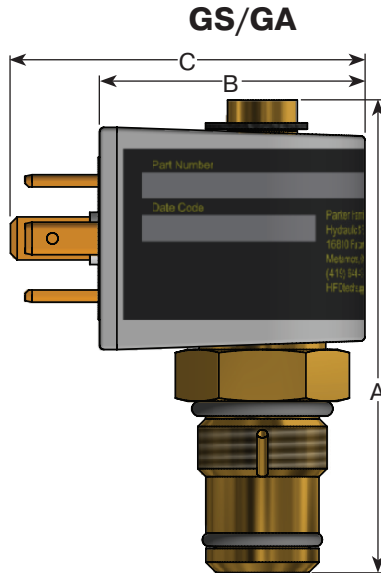

GS

Output: Dry Contact Reed Switch

- Absolute maximum carry current 1 amp (AC/DC)
- Absolute maximum switching current 500 mA (AC/DC)
- Absolute maximum voltage 125 VAC/30 VDC

Torque: 30-35 ft lbs

GA

Output: Analog 4-20 mA

Supply Voltage: 10.0 VDC - 28 VDC (Clean and Filtered)

Torque: 30-35 ft lbs

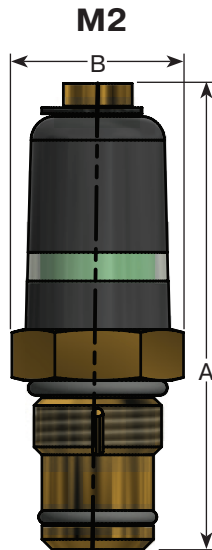
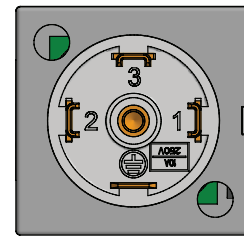

947356

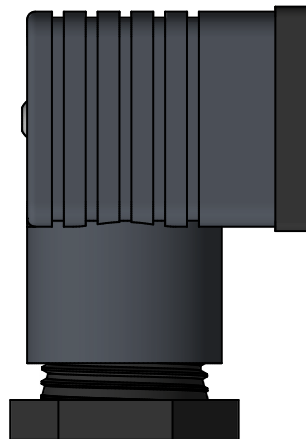

- DIN43650 standard socket
- For use with GS and GA

947355



- DIN43650 visual LED socket
- 12-35 VDC
- For use with GS

Output: Visual

Option	Description	Connection/Power	Wiring	A	B	C
				inches/mm		
GS	Reed Switch	DIN 43650 3 Pole + Earth 500mA @ 30 VDC 500mA @ 125 VAC	Pin 1 - Common Pin 2 - Normally Open Pin 3 - Normally Closed Pin 4 - Not Connected	2.74 69.6	1.54 39.1	2.06 52.3
GA	4-20mA Analog	DIN 43650 3 Pole + Earth Supply Voltage: 10 VDC - 28 VDC Output: 4-20 mA	Pin 1 - Supply (10VDC - 28VDC) Pin 2 - Common (Circuit Ground) Pin 3 - 4-20mA Out Pin 4 - Not Connected	2.74 69.6	1.54 39.1	2.06 52.3
M2	Visual	N/A	N/A	2.74 69.6	1.45 36.8	N/A

50P Series

Parts List and Service Instructions

Index	Description	Part Number 50P	
1	Head Assembly	C/F	
2	Bowl	C/F	
3	Cover	926655	
4	Cover O-ring, Nitrile	N92246	
	Cover O-ring, Fluorocarbon	V92246	
5	Vent Plug	927363	
	Vent Plug O-ring - Nitrile	N93905	
	Vent Plug O-ring - Fluorocarbon	V93905	
6	Element	See Replacement Element Table	
7	Drain Plug	927363	
	Drain Plug O-ring - Nitrile	N93905	
	Drain Plug O-ring - Fluorocarbon	V93905	
8	Bypass Valve		
	50 psid	924189	
	90 psid	927399	
Indicators¹		50 psid	90 psid
9	M2 - Visual	945661	947378
10	GS - Electrical	946201	946204
10	GA - Analog	946210	946213
Not Shown	Standard DIN 43650 Socket Kit	947356	
Not Shown ²	12-35VDC LED Visual DIN 43650 Socket	947355	
Not Shown	Manifold port O-ring - Nitrile	N92128	
Not Shown	Manifold port O-ring - Fluorocarbon	V92128	

1. DIN plugs for GA/GS indicators are sold separately. See page 121.

2. For use with 946201.

Element Service Instructions

When servicing the 50P filter, use the following procedure.

- A. Stop the system's power unit.
- B. Relieve any pressure in the filter or line.
- C. If desired, oil can be drained from filter housing by removing the drain port plug located in the head.
- D. Rotate the cover counterclockwise and remove.
- E. Remove element from housing.
- F. Place new, clean element into housing centering element over locator.
- G. Inspect cover o-ring and replace if necessary.
- H. Apply cover to filter and tighten to 45-50 ft. lbs.
- I. Replace drain plug and tighten 20-25 ft. lbs.

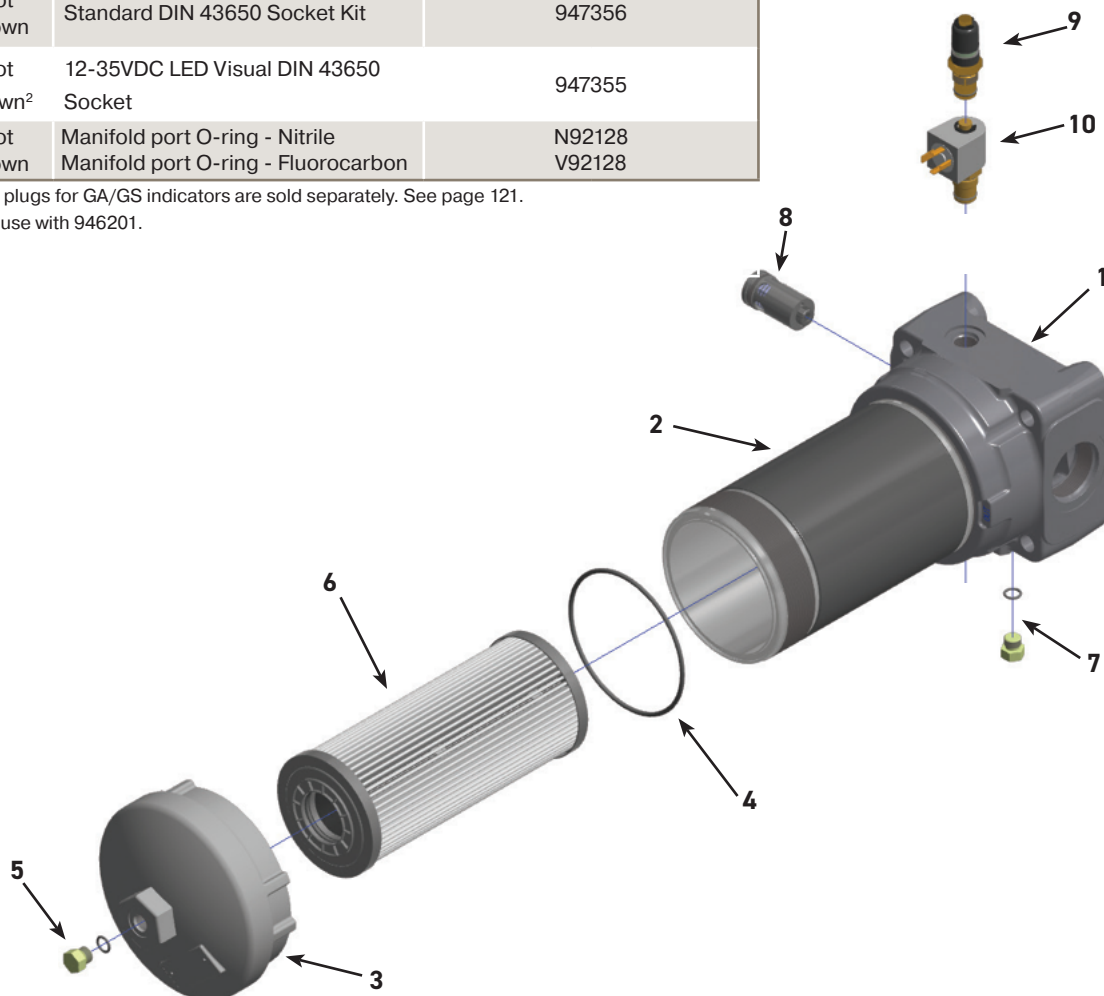

50P Series^{1,2}

High Pressure Filters

How To Order

Select the desired symbol (in the correct position) to construct a model code. Example:

BOX 1	BOX 2	BOX 3	BOX 4	BOX 5	BOX 6	BOX 7	BOX 8
50P	1	10Q	B	GS	M	S24	1

BOX 1: Filter Series	
Symbol	Description
50P	5000 PSI (MAOP)
50PR*	Reverse flow hydrostatic version

* Not available on triple length, must choose 1 or 2 in box 2.

BOX 2: Element Length	
Symbol	Description
1	Single
2	Double
3	Triple (50P only)

BOX 3: Media Code	
Symbol	Description
02Q	Microglass, 2 micron
05Q	Microglass, 5 micron
10Q	Microglass, 10 micron

BOX 4: Seal Material	
Symbol	Description
B	Nitrile
V	Fluorocarbon

BOX 5: Indicator	
Symbol	Description
P	Plugged indicator port
M2	Visual
GS	Electrical Reed Switch with DIN 43650 socket
GA	Analog 4-20mA with DIN 43650 socket

BOX 6: Bypass	
Symbol	Description
K	50 psid
M	90 psid

BOX 7: Ports	
Symbol	Description
S24	SAE-24
Y24	SAE Code 62 Flange
X22	1 3/8" Manifold ports

BOX 8: Options	
Symbol	Description
1	None

- Filters include the element you select already installed.
- This is a non-returnable product.

Replacement Elements (Fluorocarbon)

Standard Collapse			
Media	Single	Double	Triple
02Q	932668Q	932677Q	933486Q
05Q	932669Q	932678Q	933487Q
10Q	932670Q	932679Q	933488Q



Hydraulic & Fuel Filtration Division
www.parker.com/emhff

Last updated April, 2024

Parker's willingness to conduct business with Buyer is expressly conditioned on Buyer's assent to Parker's Offer of Sale. www.parker.com/saleterms