



12AT/50AT Series

Spin-On Filters

80AT/80UT Series

Dual Spin-On Filters



ENGINEERING YOUR SUCCESS.

12AT/50AT 80AT/80UT Series

Spin-On Filters

Applications for Spin-On Filters

- Mobile Equipment
- Hydrostatic Drives
- Industrial Power Units
- Reservoir Breathers



Parker's latest range of Spin-On filter technology provides users with reliable performance in a lightweight, compact and cost effective package. These solutions provide protection to critical system components in a variety of low pressure applications.

In addition to increased flow rates, Parker has expanded the product family to include new filter head configurations and flanged porting along with consistency in filter element condition options.

Recognized as a leader in product quality, Parker applies the latest in design and manufacturing techniques to deliver on our promise.

Mounting

- 2 or 6 hole pattern for flexibility

Ports

- Both NPT and SAE straight thread connections available. SAE Code 61 Flange on 80AT.

Interchangeability

- Parker canisters fit many competitors' heads. Contact Hydraulic & Fuel Filtration Division.



Color Indicating Gauges/Switches

- Identifies element condition during operation

Disposable Canister

- No mess, oil is contained inside
- Easy to handle
- Single and double length filters for longer life

Spin-On filters can be used in suction and return line filter applications with pressures to 150 psi (10.3 bar).

Improving system fluid cleanliness levels, providing better cold start performance and meeting service interval expectations are the primary objectives in the AT/UT series design. Parker filters utilize several types of filtration media to meet the demanding requirements of today's applications.

• Cellulose Media

The original and most common media is made of natural fibers. These twisted fibers are larger and more irregular than synthetic fibers - creating more resistance to flow or pressure drop.

• Synthetic Media

These man-made glass fibers are very uniform in size and shape - creating the least possible resistance to flow and providing improved efficiency to protect sensitive controls.

• Par-Gel Media

A highly absorbent copolymer laminate with an affinity for water - allows hydraulic or lubrication fluid to pass freely but water is bonded to the media and forever removed from the system.

12AT/50AT/80AT/80UT Series

Performance

Media Code	Filter Media	Beta Ratios	Particle Size/Efficiency
03B	Microglass	$\beta_3=75$	3 / 98.7%
10B	Microglass	$\beta_{10}=75$	10 / 98.7%
20B	Microglass	$\beta_{20}=75$	20 / 98.7%
03C	Cellulose	$\beta_3=2$	3 / 50%
10C	Cellulose	$\beta_{10}=2$	10 / 50%
25C	Cellulose	$\beta_{25}=2$	25 / 50%
WR	Water Removal	$\beta_{20}=2$	20 / 50%

Beta Rating	Efficiency at (X) Particle Size
$\beta_x = 2$	50.0%
$\beta_x = 20$	95.0%
$\beta_x = 75$	98.7%
$\beta_x = 200$	99.5%
$\beta_x = 1000$	99.99%

Actual results are dependent on system flow rates, fluid viscosities, and other parameters.

Flow vs. Pressure Loss

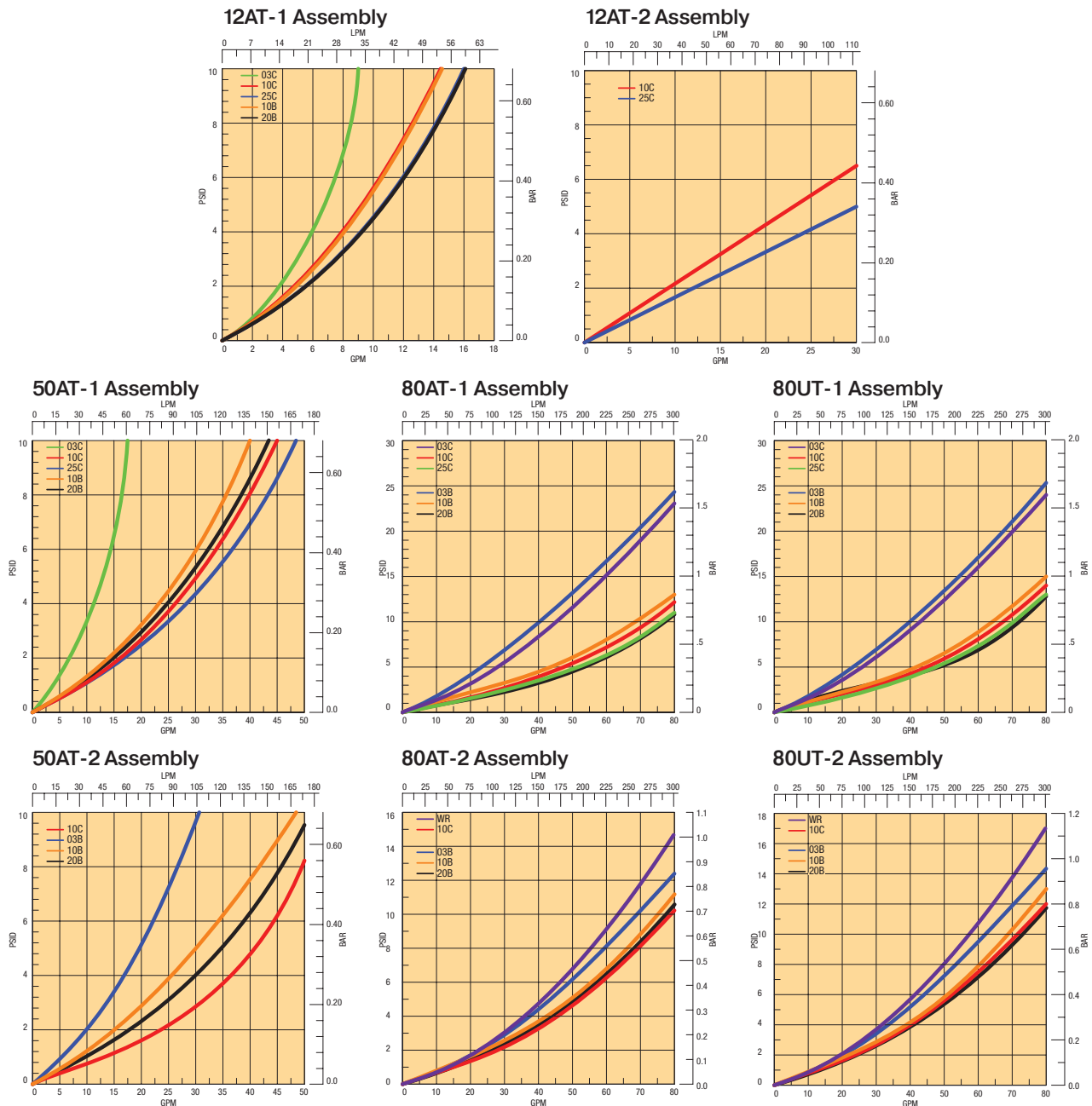

12AT Series

Spin-On Filters

Installation and Specification Data

Pressure Rating:

Maximum Allowable
Operating Pressure (MAOP):
150 psi (10.3 bar)

Design Safety Factor: 2.5:1

Operating Temperatures:

-40°F to 225°F (-40°C to 107°C)

Canister Collapse Rating:

100 psid minimum

Canister Condition Indicators:

Gauge: Color coded 15/25 psig

Gauge: Color coded vacuum

Pressure Switch: Normally open

20 +/- 2 psig
5 Amps @ 24 VDC

Vacuum Switch: Normally open

5" +/- 1" Hg
1.0 Amp @ 120 VAC

Filter Material:

Head: Aluminum

Canister: Low Carbon Steel

Shipping Weights

(approximate):

Single length: 1.6 lbs.

Double length: 2.7 lbs.

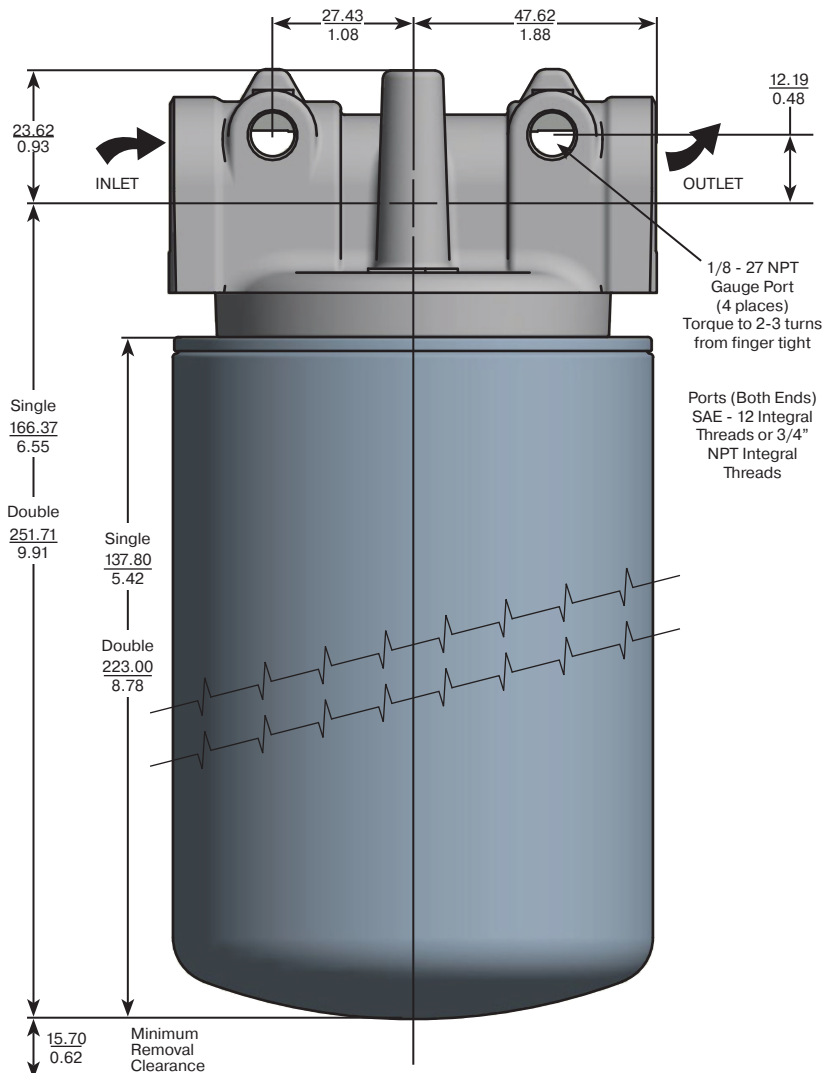
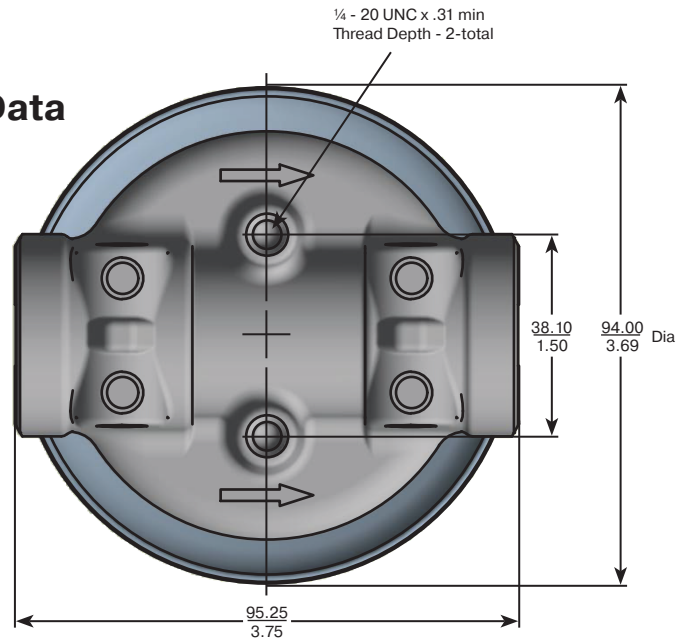

Linear Measure: $\frac{\text{millimeter}}{\text{inch}}$

Drawings are for reference only.
Contact factory for current version.

50AT Series

Spin-On Filters

Installation and Specification

Data

Pressure Rating:

Maximum Allowable
Operating Pressure (MAOP):
150 psi (10.3 bar)

Design Safety Factor: 2.5:1

Operating Temperatures:

-40°F to 225°F (-40°C to 107°C)

Canister Collapse Rating:

100 psid minimum

Canister Condition Indicators:

Gauge: Color coded 15/25 psig

Gauge: Color coded vacuum

Pressure Switch: Normally open
20 +/- 2 psig
5 Amps @ 24 VDC

Vacuum Switch: Normally open
5" +/- 1" Hg
1.0 Amp @ 120 VAC

Filter Material:

Head: Aluminum

Canister: Low Carbon Steel

Shipping Weights (approximate):

Single length: 3.9 lbs.

Double length: 4.8 lbs.

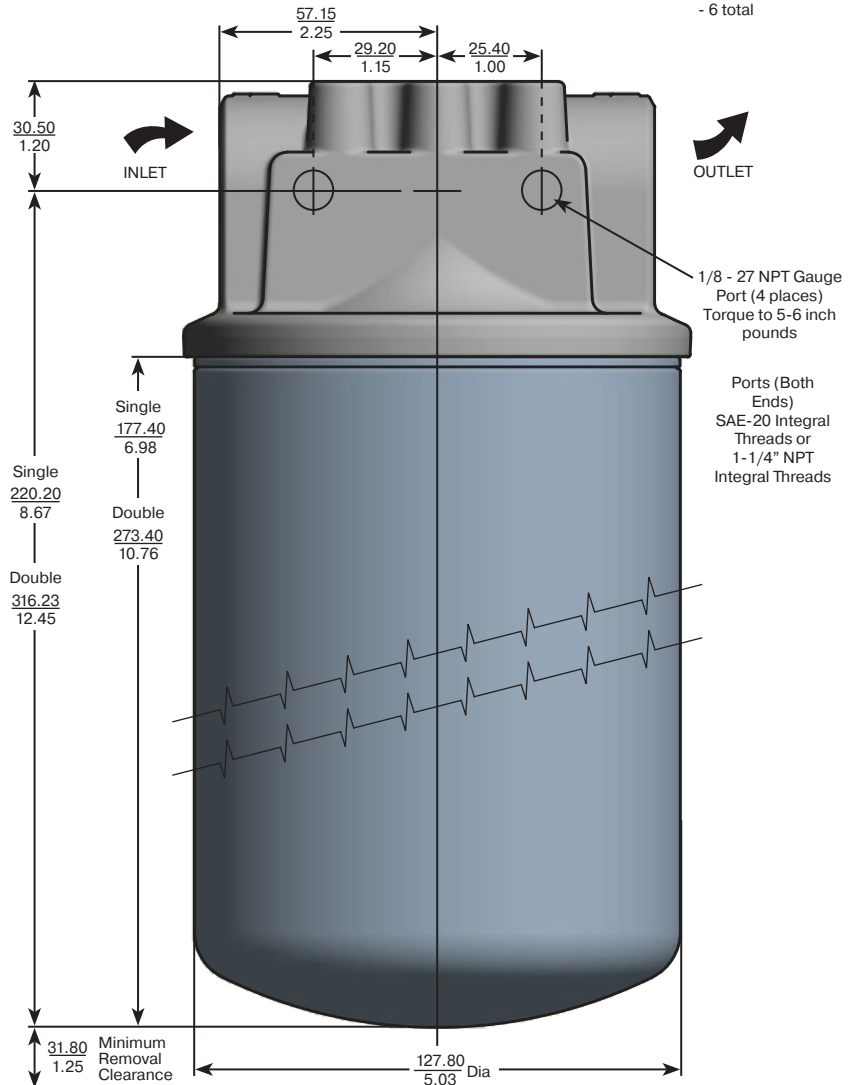
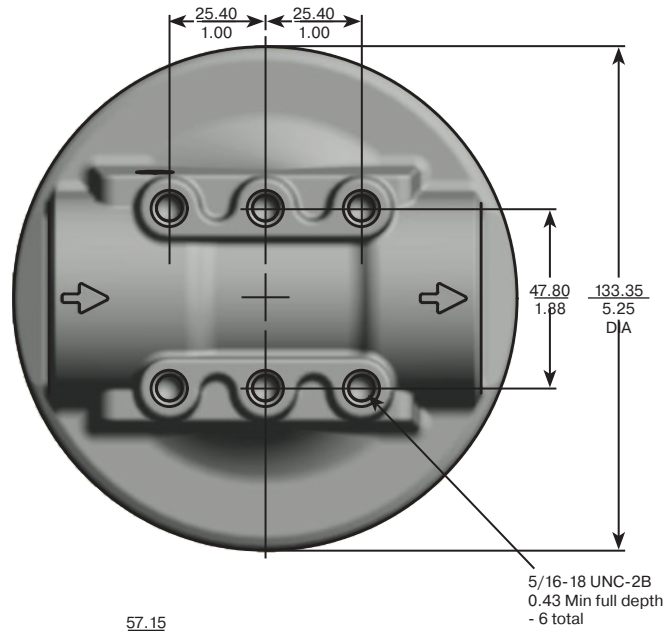

Linear Measure: $\frac{\text{millimeter}}{\text{inch}}$

Drawings are for reference only.
Contact factory for current version.

80AT Series

Dual Spin-On Filters

Installation and Specification Data

Pressure Rating:

Maximum Allowable
Operating Pressure (MAOP):
150 psi (10.3 bar)

Design Safety Factor: 2.5:1

Operating Temperatures:

-40°F to 225°F (-40°C to 107°C)

Canister Collapse Rating:

100 psid minimum

Canister Condition Indicators:

Gauge: Color coded 15/25 psig

Gauge: Color coded vacuum

Pressure Switch: Normally open
20 +/- 2 psig
5 Amps @ 24 VDC

Vacuum Switch: Normally open
5" +/- 1" Hg
1.0 Amp @ 120 VAC

Filter Material:

Head: Aluminum

Canister: Low Carbon Steel

Shipping Weights (approximate):

Single length: 11.3 lbs.

Double length: 13.0 lbs.

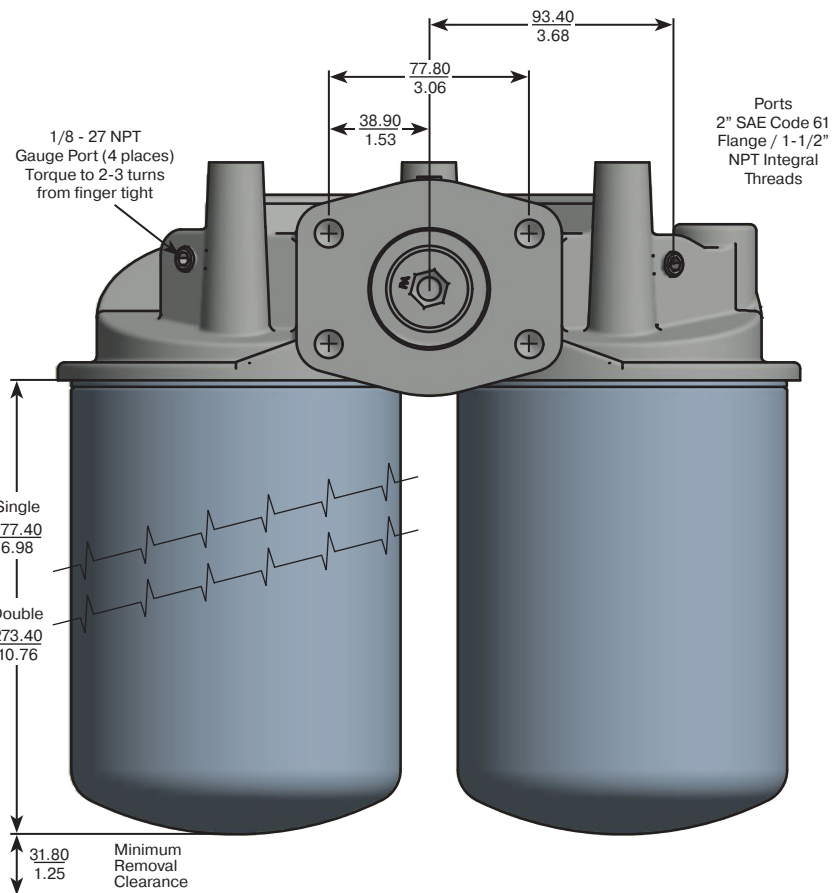
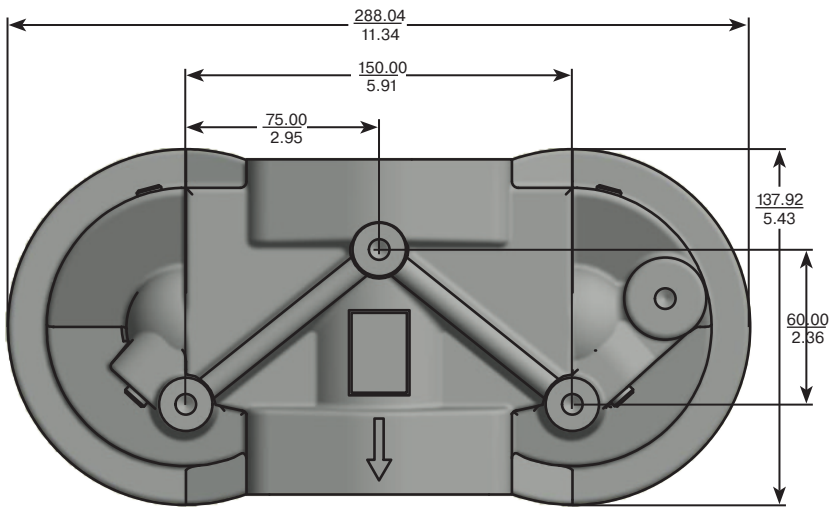

Linear Measure: $\frac{\text{millimeter}}{\text{inch}}$

Drawings are for reference only.
Contact factory for current version.

80UT Series

Over/Under Spin-On Filters Installation and Specification Data

Pressure Rating:

Maximum Allowable
Operating Pressure (MAOP):
150 psi (10.3 bar)

Design Safety Factor: 2.5:1

Operating Temperatures:

-40°F to 225°F (-40°C to 107°C)

Canister Collapse Rating:

100 psid minimum

Canister Condition Indicators:

Gauge: Color coded 15/25 psig
Gauge: Color coded vacuum

Pressure Switch: Normally open
20 +/- 2 psi
5 Amps @ 24 VDC

Vacuum Switch: Normally open
5" +/- 1" Hg
1.0 Amp @ 120 VAC

Filter Material:

Head: Aluminum
Canister: Low Carbon Steel

Shipping Weights (approximate):

Single length: 6.9 lbs.
Double length: 8.6 lbs.

Linear Measure: $\frac{\text{millimeter}}{\text{inch}}$

Drawings are for reference only.
Contact factory for current version.

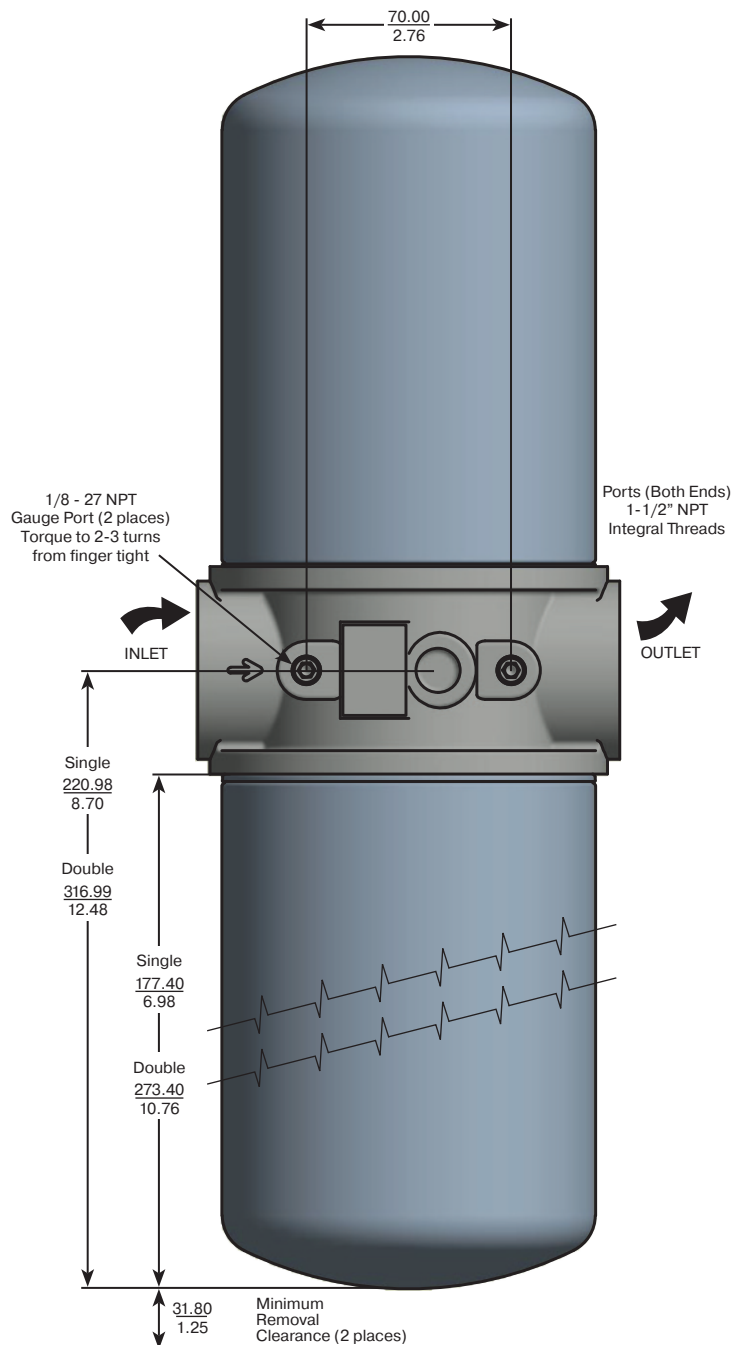
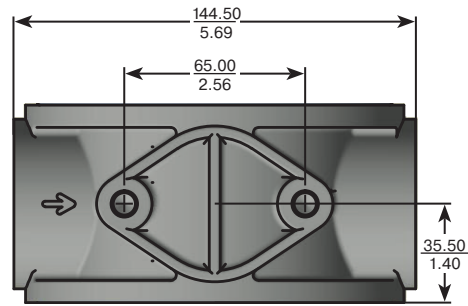

12AT/50AT/80AT/80UT Series

Spin-On Filters

Installation Instructions

- 1. DANGER!** Read and follow all safety instructions. Failure to do so could result in serious bodily injury or death.
- Turn off power supply to pumping unit.
- Tag pumping unit out of service for filter change.
- Remove the old filter, while collecting all spilled fluid. Dispose of the old filter in accordance with local, state or federal regulations.
- Apply a thin film of lubricating oil to the gasket of the new filter.
- Thread new filter on the flow adapter or manifold until the gasket makes contact. Tighten according to filter label.
- Turn on fluid supply.
- Pressurize the system and check for leaks.

Operation Instructions

- 1. WARNING!** A pressure differential indicator must be installed for any system capable of generating more than 25 psid across the filter.
- Filter unit must be installed using a suitable mounting device or rigid piping.
- Filter unit must be installed with flow in proper direction.
- Filter should be inspected every six months and changed annually when slow flow occurs.
- Water absorbing filters - when the differential pressure reaches 20-25 psid the filter could be plugged with water and should be immediately replaced. Failure to replace could result in internal filter rupture resulting in water down stream.

- If water stoppage is suspected, remove the water absorbing filter and pour the contents in a jar. If fluid is cloudy or water separates in the jar, the filter is most likely plugged with water. If water is excessive in the jar it may be necessary to have the tank cleaned or drained prior to further use.

Return Line Applications

- 25 lb bypass in flow adapter recommended.
- Filter unit must be installed in the circuit just before the reservoir. DO NOT use a shutoff valve in the return line for the filter that is being changed. A check valve is acceptable.
- Filter unit must be sized to accept the total flow during discharging from the cylinders and actuators.

Suction Side Applications

- 3-5 lb bypass in flow adapter recommended to prevent pump cavitation.
- A vacuum gauge is recommended to monitor filter condition.
- Cavitation of the pump can be a problem with the filter on the suction line. Always try to minimize restriction by oversizing the filter, or by using a microglass media.

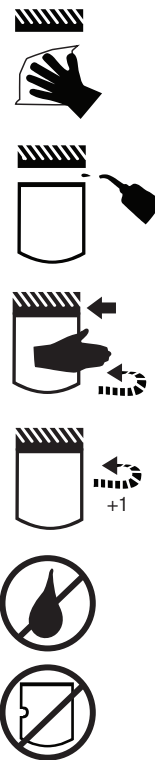

12AT/50AT/80AT/80UT Series

Spin-On Filters

Accessory Parts List

Description	Part Number
Gauge - 15 psig	936911
Gauge - 25 psig	936912
Vacuum gauge	926909
Vacuum switch	936949
Pressure switch - 25 psig	926923

Indicating Pressure Gauge (15 PSIG)



Indicating Pressure Gauge (25 PSIG)



Indicating Vacuum Gauge



Vacuum Switch

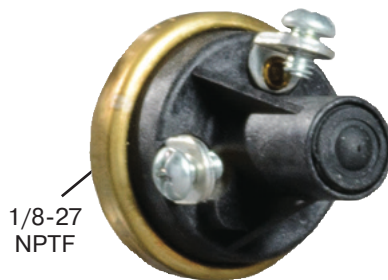

Pressure Switch



Seals Included 50AT

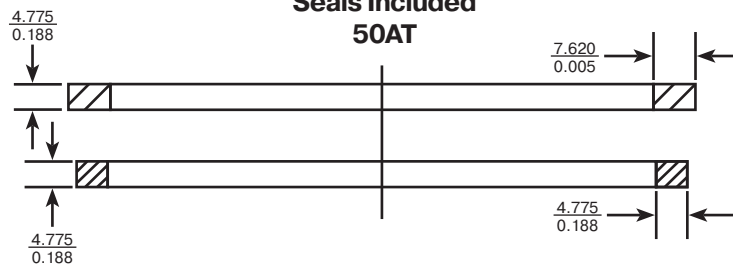

Linear Measure: millimeter
inch

12AT/50AT/80AT/80UT Series

Spin-On Filters

Reservoir Breather

Sizing

Select the proper size canister for the maximum rate of reservoir draw down or air exchange rate. As a rule of thumb, clean pressure drop should be limited to 0.18 psid (5" H₂O).

A pipe flange, weld collar, etc. may be used to connect the adapter kit to the reservoir. Make sure that air is not able to leak around the adapter. When mounting on the side of the reservoir, make sure the installation is above the surface of the fluid.

Recommended canister change out is after 500 hours of operation. More frequent replacement may be required when operated in heavily contaminated areas such as grinding operations, primary metal mills, and on mobile equipment. Under such conditions, increase replacement frequency to every 250 hours.

Model	Air Rating*	Canister	Adapter Kit
12AT-03C	1 micron	926543	926876
12AT-10C	2 micron	921999	926876
12AT-25C	5 micron	925023	926876
50AT-03C	1 micron	926541	926875
50AT-10C	2 micron	926169	926875
50AT-25C	5 micron	926170	926875

* 99% Removal efficiency for particles larger than the stated size in air.

Graphs are for 03C canisters only. Total pressure drop across canister, adapter, and pipe may be found by adding pressure drops below:

- + 1.5% for each inch of 12AT adapter or 3/4" pipe used.
- + 3.0% for each 3/4" elbow used.
- + 1.0% for each inch of 50AT adapter or 1-1/4" pipe used.
- + 2.0% for each 1-1/4" elbow used.



Typical Installations mounted on side or top of reservoir

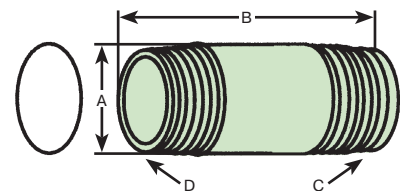
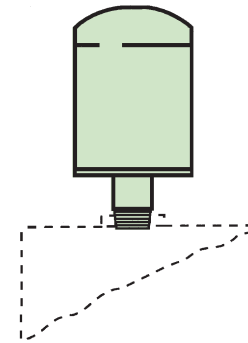
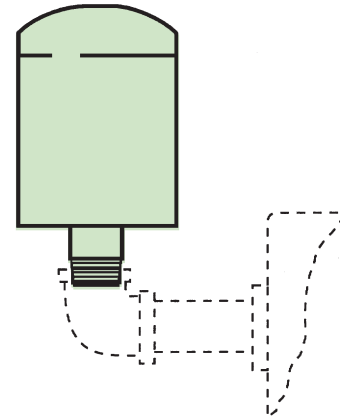

	12AT	50AT
PN	926876	926875
A	26.70(1.05)	42.70(1.66)
B	66.80(2.63)	85.10(3.35)
C	3/4" NPT	1-1/4" NPT
D	1"-12 UN	1-1/2"-16 UN

Allow 1.25" for canister removal clearance

Linear Measure: millimeter
inch

12AT/50AT/80AT/80UT Series¹

Spin-On Filters

How To Order

Select the desired symbol (in the correct position) to construct a model code. Example:

BOX 1	BOX 2	BOX 3	BOX 4	BOX 5	BOX 6	BOX 7	BOX 8
12AT	1	10C	B	P	G	S12	H

BOX 1: Filter Series ^{2,3}	
Symbol	Description
12AT	20 GPM Nominal
50AT	50 GPM Nominal
80AT	80 GPM Nominal-Dual
80UT	80 GPM Nominal-Dual

BOX 2: Element Length	
Symbol	Description
1	Single
2	Double

BOX 3: Media Code	
Symbol	Description
12AT-1	
10B	Microglass, 10 micron
20B	Microglass, 20 micron
03C	Cellulose, 3 micron
10C	Cellulose, 10 micron
25C	Cellulose, 25 micron
12AT-2	
10C	Cellulose, 10 micron
25C	Cellulose, 25 micron
50AT/80AT/80UT-1	
03B	Microglass, 3 micron
10B	Microglass, 10 micron
20B	Microglass, 20 micron
03C	Cellulose, 3 micron
10C	Cellulose, 10 micron
25C	Cellulose, 25 micron
50AT/80AT/80UT-2	
03B	Microglass, 3 micron
10B	Microglass, 20 micron
20B	Microglass, 20 micron
10C	Cellulose, 10 micron
WR	Water Removal

BOX 4: Seal Material	
Symbol	Description
B	Nitrile

BOX 5: Indicator	
Symbol	Description
P	Gauge Ports Plugged

BOX 6: Bypass	
Symbol	Description
G	25 psid (1.7 bar)
C	15 psid (1.03 bar)
P	3 psid (0.2 bar)
X	No bypass

BOX 7: Ports	
Symbol	Description
12AT	
S12	SAE-12 Integral Threads
N12	3/4" NPT Integral Threads
50AT	
S20	SAE-20 Integral Threads
N20	1-1/4" NPT Integral Threads
80AT	
Y32	2" SAE Code 61 Flange / 1-1/2" NPT Integral Threads
80UT	
N24	1-1/2" NPT Integral Threads

BOX 8: Gauge Port	
Symbol	Description
N	None
H	Inlet & Outlet, both sides (all ports drilled & tapped)

Notes:

- The filter includes the element you select already installed.
- Selecting 80AT or 80UT in Box 1 requires the selection of "G" in Box 6 and "H" in box 8.
- Nominal flow rates for single length filters:
12AT - 12GPM; 50AT - 35 GPM;
80AT/80UT - 55 GPM.

Replacement Canisters

Media	12AT-1	12AT-2	50AT/80AT/80UT-1	50AT/80AT/80UT-2
03B	N/A	N/A	934200	932073
10B	928763	N/A	928766	929445
20B	928764	N/A	928767	929446
03C	926543	N/A	926541	N/A
10C	921999	946785	926169	927736
25C	925023	946784	926170	N/A
WR	N/A	N/A	N/A	FA511-10W



Hydraulic & Fuel Filtration Division

www.parker.com/emhff

Last updated August 4th, 2023

Parker's willingness to conduct business with Buyer is expressly conditioned on Buyer's assent to Parker's Offer of Sale. www.parker.com/saleterms