

Valvola OVERCENTER doppio effetto in linea
In line, double effect COUNTERBALANCE valve
 mod. OVC-DE-L

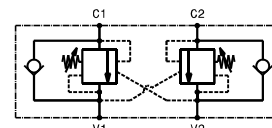
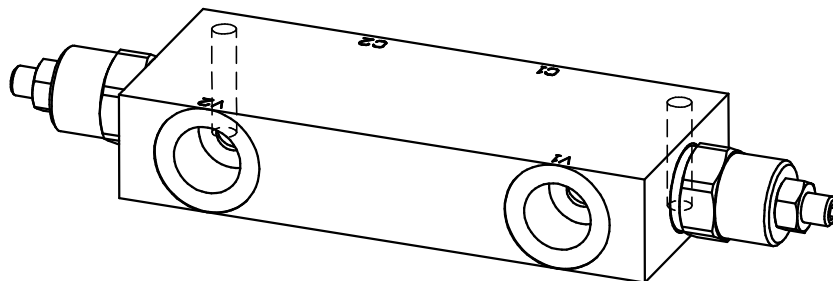

Versione con corpo in alluminio o in acciaio
Aluminium or steel body version

Pressione massima <i>Max pressure</i>	350 bar 5000 psi
Rapporto di pilotaggio standard <i>Standard pilot ratio</i>	4,25:1 (G3/8" - G1/2"), 4:1 (G3/4" - G1")
Rapporto di pilotaggio a richiesta <i>Pilot ratio upon request</i>	3:1 8:1 10:1
Dati e tarature ottenuti usando olio con viscosità 30 cSt a 50°C <i>Performances and calibrations are carried out by using hydraulic oil with 30 cSt viscosity at 50°C</i>	
Viscosità consigliate <i>Recommended viscosity</i>	10 ÷ 420 cSt
Temperature di lavoro <i>Working temperature</i>	-20 ÷ +90 °C
Filtrazione assoluta <i>Absolute filtration</i>	25 µ

Modello <i>Type</i>	V1, V2 C1, C2	Portata max <i>Max. flow</i>
OVC-DE-L-38	3/8"GAS	40 l/min 10.5 gpm
OVC-DE-L-12	1/2"GAS	70 l/min 18 gpm
OVC-DE-L-34	3/4"GAS	110 l/min 26 gpm
OVC-DE-L-10	1"GAS	120 l/min 32 gpm

Taratura Setting			
La valvola deve essere tarata almeno 1.3 volte la massima pressione indotta dal carico <i>The valve must be set at least 1.3 times maximum load induced pressure</i>			
Codice <i>Code</i>	Taratura standard <i>Standard setting (Q=5 l/min)</i>	Campo di taratura <i>Adj. Pressure range</i>	Colore molla <i>Spring color</i>
01	100 bar 1450 psi	20+200 bar 290+2900 psi	Bianco White
02	280 bar 4000 psi	50+350 bar 725+5000 psi	Nero Black

Regolazioni - Adjustments

Vite esterna esagono incassato
Leakproof hex socket screw

Piombatura
Sealing cap

Cappellotto
Cap

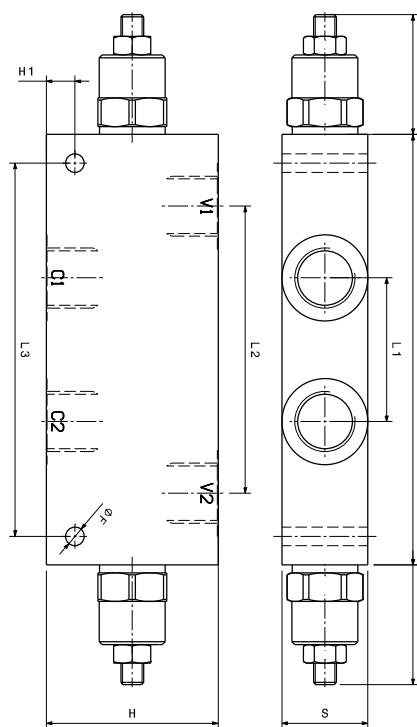

Modello <i>Type</i>	L	H	S	L1	L2	L3	L4	H1	F
OVC-DE-L-38	150	60	30	50	100	130	42	10	6.5
OVC-DE-L-12	150	60	30	50	100	130	42	10	6.5
OVC-DE-L-34	190	70	40	64	138	170	46	10	8.5
OVC-DE-L-10	190	70	50	64	132	170	46	10	8.5

Sigla di ordinazione / Ordering code

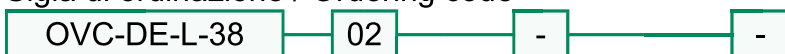

Modello <i>Type</i>	Codice taratura <i>Setting code</i> 01, 02	Codice regolazione <i>Adjustment code</i> -, C, D	- Alluminio / Aluminium A Acciaio / Steel
------------------------	--	---	--

For flow diagram see
 PRESSURE DROP OVERCENTER VALVES (8) +
 PRESSURE DROP OVERCENTER VALVES (9)

I dati non sono impegnativi, CBF si riserva di apportare modifiche senza preavviso.
The specifications are not binding, CBF reserves the right to introduce modifications without notice.