

Valvola di blocco pilotata a doppio effetto in linea
In line, double effect, pilot operated check valve
mod. VBD-L

Versione con corpo in alluminio o in acciaio
Aluminum or steel body version

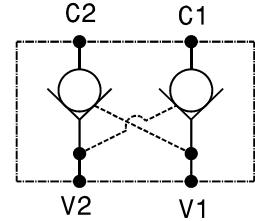

Modello Type	V C	Rapporto di pilotaggio Pilot ratio	Portata massima Max Flow	Pressione massima Max pressure	Pressione di apertura Cracking pressure
VBD-L-14	1/4" GAS	4:1	20 l/min 5.3 gpm	350 bar 5000 psi	3 bar 43 psi
VBD-L-38	3/8" GAS	4:1	35 l/min 9 gpm	350 bar 5000 psi	3 bar 43 psi
VBD-L-12	1/2" GAS	4:1	50 l/min 13 gpm	350 bar 5000 psi	2 bar 29 psi
VBD-L-34	3/4" GAS	4:1	80 l/min 21 gpm	250 bar 3600 psi	2 bar 29 psi

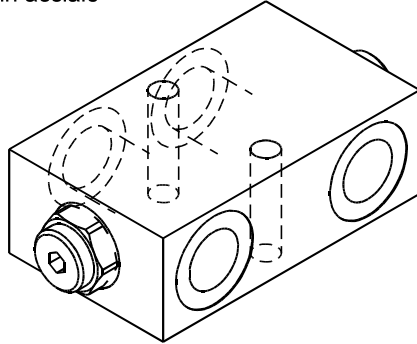
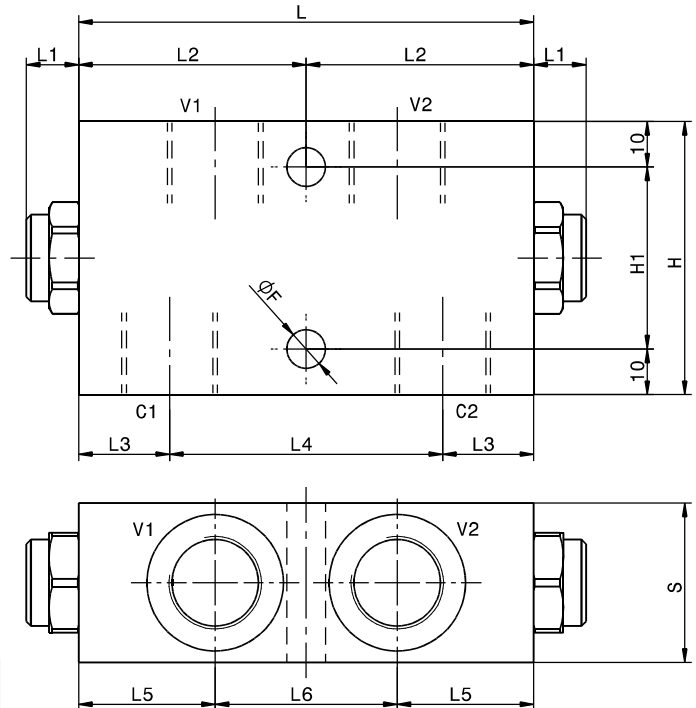

Dati e tarature ottenuti usando olio con viscosità 30 cSt a 50°C
Performaces and calibrations are carried out by using hydraulic oil with 30 cSt viscosity at 50°C

Viscosità consigliate Recommended viscosity	10 ÷ 420 cSt
Temperature di lavoro Working temperature	-20 ÷ +90 °C
Filtrazione assoluta Absolute filtration	25 µ

Dimensioni Dimensions	L	L1	L2	L3	L4	L5	L6	H	H1	S	F
VBD-L-14	100	12	50	20	60	35	30	60	40	30	6.5
VBD-L-38	100	12	50	23	54	35	30	60	40	30	6.5
VBD-L-12	100	12	50	20	60	30	40	60	40	35	8.5
VBD-L-34	110	21	55	23	64	32.5	45	70	50	40	8.5

Sigla di ordinazione / Ordering code

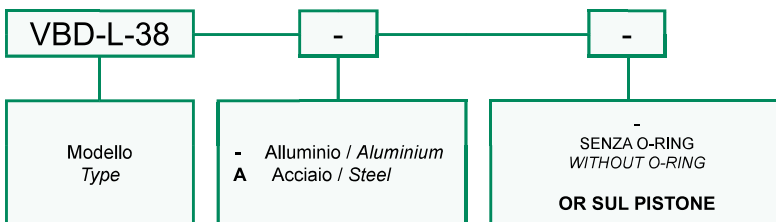

I dati non sono impegnativi, CBF si riserva di apportare modifiche senza preavviso.
The specifications are not binding, CBF reserves the right to introduce modifications without notice.