

Indicators Series

FMU Δp -Indicators and Pressure Indicators
Max 420 bar



Measuring critical system parameters is essential

Reliable and continuous control of the filter in all applications

The FMU range of filter condition indicators are designed for use on a wide range of Parker filters and competitive interchange filters. Maximum pressure 420 bar. A comprehensive range of high quality indicators for mobile, industrial and marine applications.



Contact Information:

Parker Hannifin
Hydraulic Filter Division Europe

European Product Information Centre
Freephone: 00800 27 27 5374
(from AT, BE, CH, CZ, DE, EE, ES, FI, FR, IE, IT, PT, SE, SK, UK)
filtrationinfo@parker.com

www.parker.com/hfde

Product Features:

- The FMU range of filter condition indicators, designed for use on a wide range of Parker filters.
- Accurate visual, electronic or electrical filter condition feedback.
- Maximum pressure 420 bar.
- Mobile, industrial and marine applications.

Indicators Series

FMU Δp -Indicators and Pressure Indicators

Features & Benefits

Features	Advantages	Benefits
Indicators fatigue tested to full pressure rating	Reliable indicators for heavy duty applications	Reliable and continuous control of the filter in all applications
Cartridge screw-in type indicators	Easy mounting	Reliable sealing, no leakage
Visual, electrical and electronic indicators available	Check element condition at a glance	Optimises element life, prevents bypassing
	Right style for the application	Match your system's electrical connections
Several indication settings	Optimized for each bypass setting	Right indicator for application
Visual indicators	Local monitoring of the element condition	Reliable low cost indicator
Electrical indicator with change-over switch	Option of Normally Open (N.O.) and Normally Closed (N.C.) function	Approved for low voltage and high voltage use including machine control systems and PLC's
Electrical indicator with 4 LEDs	Thermal lock-out	No false alarm because of low temperature oil
	Visual early warning with yellow LED	Allows time to schedule element change
	Pre-alarm with yellow LED and wired output	Indicates upcoming element change
	Alarm with red LED and wired output	Clear indication for element change
Programmable and ATEX certified indicators available	Right indicators for special applications	Improved machine surveillance

Typical Applications

- Industrial equipment
- Mobile equipment
- Marine/offshore applications

The Parker FMU Series Differential Pressure Indicators

The FMU range of filter condition indicators, are designed for use on a wide range of Parker filters and suitable for competitive interchange (consult Parker Filtration for details).

Ideal for giving accurate visual, electronic or electrical feedback of filter element condition, in order to facilitate effective maintenance and ensuring hydraulic systems, marine/mobile or industrial are protected from particulate contamination.



Specification

Maximum operating pressure:

420 bar (250 bar for aluminium).

Maximum differential pressure:

210 bar.

Working temperature range:

-20°C to +85°C with fluoroelastomer seals, -40°C to +85°C with nitrile and EPDM seals.

Material of housing:

Brass, aluminium or stainless steel.

Seals:

Fluoroelastomer, Nitrile or EPDM.

Mounting torque:

max. 75 Nm

(max. 50 Nm for aluminium indicator body & filter housing)

The differential pressure values of standard indicator models:

1.2 bar ± 0.2

1.5 bar ± 0.2

2.5 bar ± 0.3

5.0 bar ± 0.5

7.0 bar ± 0.5

8.5 bar ± 0.5

(Indicators for other differential pressure values are optional).

FMU Δp – Indicators are typically used with the following filters:

Heavy duty filters: GS, SF1040, DF2035, DF2050, DFH2060, DF2070, DF2089, DF2110 Note: FMU-Block is required to connect indicator to filter.	U12H	1.0 and 1.5 bar
Medium pressure filters series: 45M. High pressure filters series: 70L, 70T, 70B, 5000, 7100 and 7200. Heavy duty filter series: 130M, DF2145.	U12H	2.5 bar
High pressure filters without bypass valve: 70L, 70T, 70B, 7100 and 7200.	U12H	7.0 bar
Medium and low pressure filter series; Note for PD Range only 2.5 bar indicators are available: 15CN, 40CN, 80CN, 22PD, 32PD, 15P, 30P, 40RF, 50RF, IL8, 12M, 22M, 16P, 26P, 36P. Also heavy duty filter DF40.	U14M	1.2 and 2.5 bar
High pressure filters 18P, 28P, 38P, FDA, FDB	U14H	2.5 and 5.0 bar

Indicators Series

FMU Δp-Indicators and Pressure Indicators

FMUT Electrical

Rated voltage	Non-inductive load (A)				Inductive load (A)				Inrush current (A)	
	Resistive load		Lamp load		Inductive load		Motor load		N.C.	N.O.
	N.C.	N.O.	N.C.	N.O.	N.C.	N.O.	N.C.	N.O.		
125VAC	5		1.5	0.7	3		2.5	1.3	20 max.	10 max.
250VAC	3		1.0	0.5	2		1.5	0.8		
8VDC	5		2		5	4	3			
14VDC	5		2		4	4	3			
30VDC	4		2		3	3	3			
125VDC	0.4		0.05		0.4	0.4	0.05			
250VDC	0.2		0.03		0.2	0.2	0.03			

Enclosure class	IP65
Electrical connector	DIN 43650
Overtoltage category	II (EN61010-1)

Contact configuration

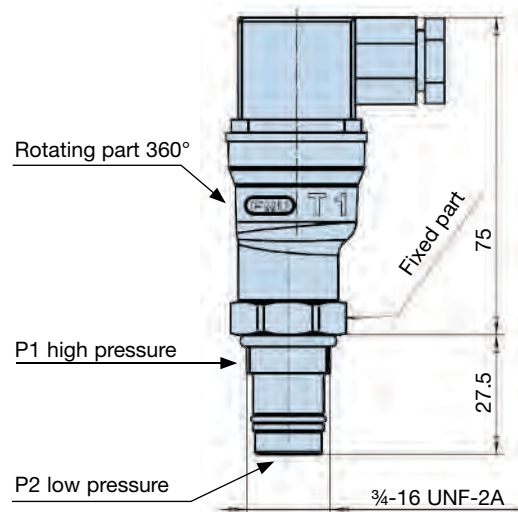
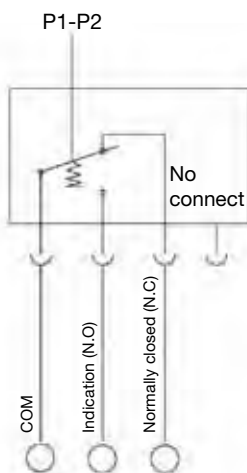

FMUM3 Visual Auto Reset/FMUM1 Visual Manual Reset

Operation

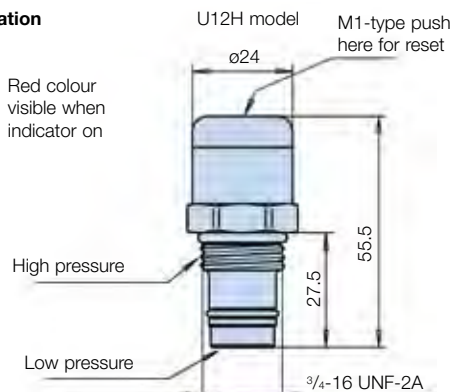

Operation

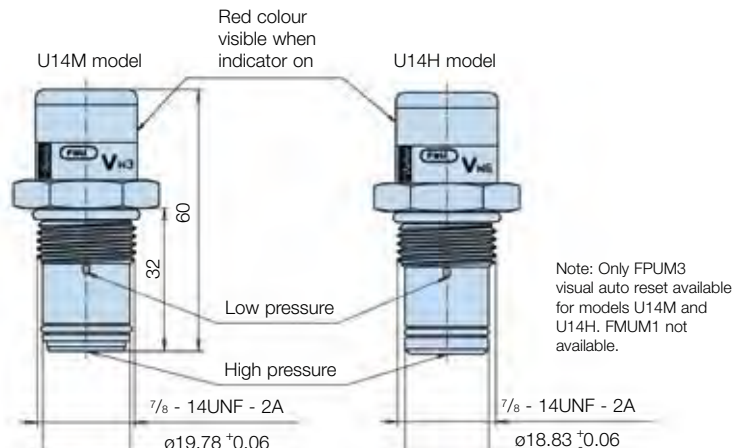

FMUF Electronic

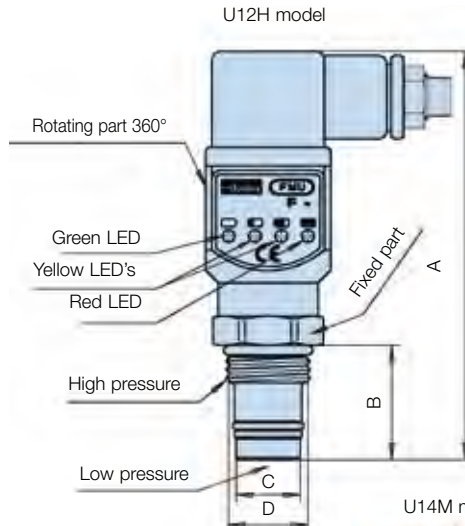
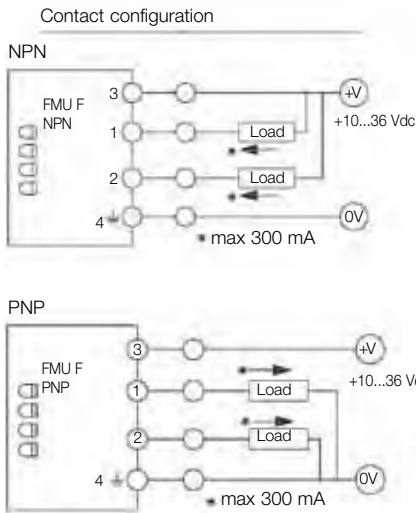

	U12H	U14M	U14H
A	98	105	105
B	27.5	32	32
C	∅16.2 ±0.05	∅19.78 ± 0.06	∅18.83 ± 0.06
D	³ / ₄ -16 UNF-2A	⁷ / ₈ -14 UNF-2A	⁷ / ₈ -14 UNF-2A

Thermal lock-out (standard setting +20°C)

- Indicator operates only when temperature is above setting.
- Green LED is blinking if temperature is lower. (not in U12H)

Ind. press. setting	LED status				Output
	G	Y1	Y2	R	
< 50 %	⊗				-
50 %	⊗	⊗			-
75 %	⊗	⊗	⊗		2 active
100 %	⊗	⊗	⊗	⊗	1 active

Enclosure class	IP65
Electrical connector	DIN 43650, cable connection PG9 or optionally M12 4-pin
Input supply voltage	+10 to 36 Vdc
*Indication output	max. 300 mA/36 Vdc
Output type:	N.O. or N.C./NPN or PNP

Note: Do not connect output terminals 1 or 2 directly (without load) to power supply terminals, because this will damage the equipment.

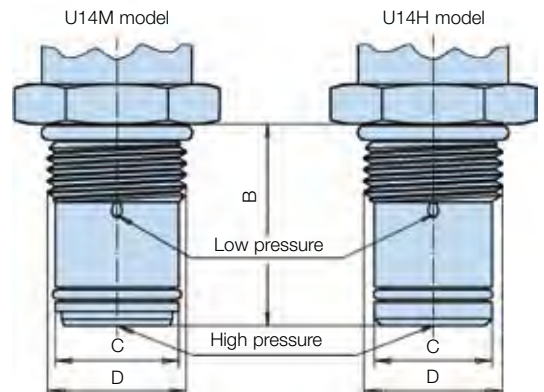

Safety feature: The 250 bar U14M indicator does not fit into the U14H cavity, which is used in 420 bar filters

FMUL1 Programmable



Dimensions: see FMUF electronic Δp-indicator

Programmable Δp-indicator

All settings adjustable (settings made via PC) Connections cable and software available from Parker

- 4 LEDs giving visual indication:
 - Green (G): Power ON
 - Yellow 1 (Y1): Pre-alarm 1 (presetting 50%)
 - Yellow 2 (Y2): Pre-alarm 2 (presetting 75%)
 - Red (R): Indication (presetting 100%)
- two independently programmable indication outputs
 - can be set independently from each other and LED setting
 - output type: NPN or PNP
 - switching type: N.O. or N.C.
- setting range: 0,5 ... 10 bar
- thermal lock-out range: 0 ... 100°C
- includes a microchip with memory logs
 - number of alarms: max 65535
 - time indication on (output 1): max 1092 hours
 - time power on (running hours): max 7 1/2 years
 - upload and reset via PC

Indicators Series

FMU Δp-Indicators and Pressure Indicators

Ordering Information

Product configurator

Box 1	Box 2	Box 3	Box 4	Box 5	Box 6	Box 7	Box 8
FMU	M3	K	V	M	U14	H	

Code	
Indicator series	Code
Filter monitoring unit	FMU

Box 2 Filter type	
Differential pressure indicator	Code
Visual manual reset	M1*
Visual autoreset	M3
Electrical	T1
Electronic 4 LED, PNP, N.O.	F1
Electronic 4 LED, NPN, N.O.	F2
Electronic 4 LED, PNP, N.C.	F3
Electronic 4 LED, NPN, N.C.	F4
Programmable with memory logs	L1
Ex version	X1

Box 3 Indicator setting		
Indicator setting	Standard	Code
1.0 bar (14 psi)	c	F
1.2 bar (17 psi)	a	G
1.5 bar (21 psi)	c	H
2.5 bar (35 psi)	a, b, c	K
5.0 bar (70 psi)	b	M
7.0 bar (98 psi)	c	N
8.5 bar (125 psi)		P

Standard settings:
a: U14M, former -W3
b: U14H, former -W6
c: U12H, former -F6

Box 4 Seal type	
Seal material	Code
Nitrile	B
Fluorelastomer	V
EPDM	E
Neopren	N

Box 5 Indicator body	
Indicator body	Code
Aluminium (Box 7, code M)	A
Brass (Box 7, code M and H)	M
Stainless steel	R

Box 6 Thread connection	
Thread connection	Code
3/4" - 16UNF-2A	U12
7/8" - 14UNF-2A	U14

Box 7 A - class products Max Pressure	
Max pressure	Code
CN, 15/30P & 22/32 PP Series	M
45M, 130M, 70P & 18/28/38P	H

Box 8 Options	
Options	Code
Standard	omit
Other options	factory supplied

Note: F and L type indicators. Non-standard thermal lockout settings shown here.

FMUX ATEX Approved Electronic

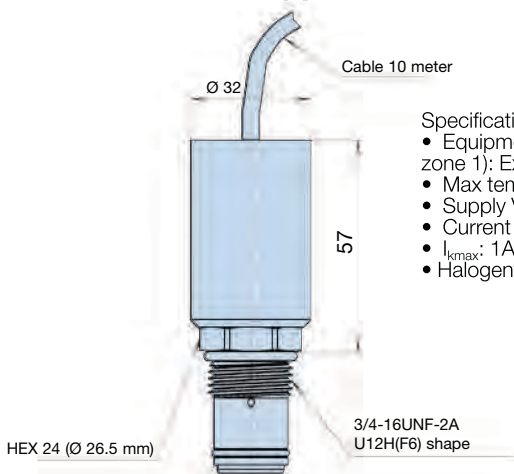

- Specification:
- Equipment category 2 (for zone 1): Ex II 2 GD Eex m II T6
 - Max temperature 85°C
 - Supply Voltage: 10 – 36 Vdc
 - Current 300 mA (max)
 - I_{kmax}: 1A
 - Halogenfree cable

Indicator type X1: ATEX Δp-indicator

Electronic indicator accordant with ATEX 94/9/EC directive: (Ex) II 2 GD Eex mII T6.
Degree of protection IP66. X1 refers to NPN, N.O. (see electronic F Type).
Other output options are available by request.

Connection cable + software for programmable indicator L1

Connection cable for PC serial connection and software for indicator settings and utilising memory logs.

Ordering Code: 905075030

Seal kits (fluoroelastomer)

Indicators with thread connection U12H (former -F6)
Indicators with thread connection U14M (former -W3)
Indicators with thread connection U14H (former -W6)

Ordering code

911045078
911045086
911045087

Note 1: Part numbers featured with bold highlighted codes will ensure a 'standard' product selection.
Note 2: Alternate displayed part number selection will require you to contact Parker Filtration for availability.

Pressure Indicators for Low Pressure Filters

ETF Filter

Visual pressure indicator
Code G2
mm (inches)

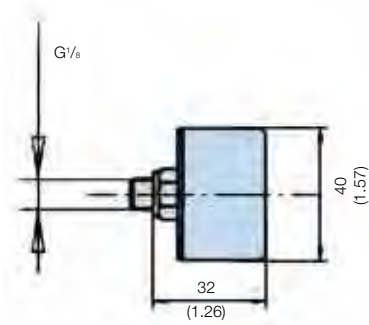

48 Vdc electrical indicator 1.0 bar
Code S2/S3
mm (inches)

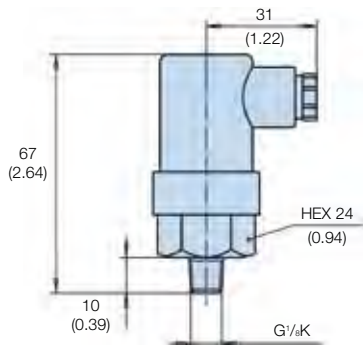

250 VAC electrical indicator 1.0 bar
Code S4
mm (inches)

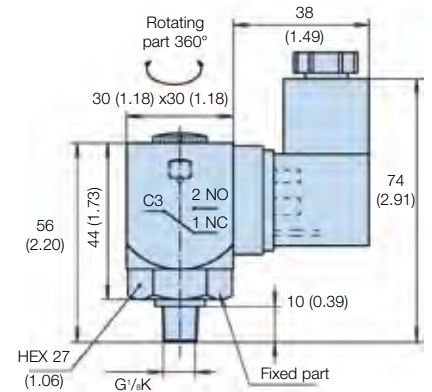

Option	Description	Connection/Voltage	Wiring	Part number						
G2	Visual indicator 1.0 bar	N/A	N/A	FMUG2EBPG02L						
S2/S3	Electrical indicator 1.0 bar	42 Vdc max	 Select either normally open (NO) or normally closed (NC)	FMUS2FBMG02L (NO switch) or FMUS3FBMG02L (NC switch)						
S4	Electrical indicator 1.0 bar	250 Vac max	 <table border="1"> <tr><td>1</td><td>NC</td></tr> <tr><td>2</td><td>NO</td></tr> <tr><td>3</td><td>C</td></tr> </table>	1	NC	2	NO	3	C	FMUS4FBMG02L
1	NC									
2	NO									
3	C									

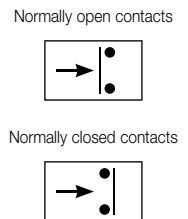

TTF, BGT and TPR

Indicator PS pressure switch

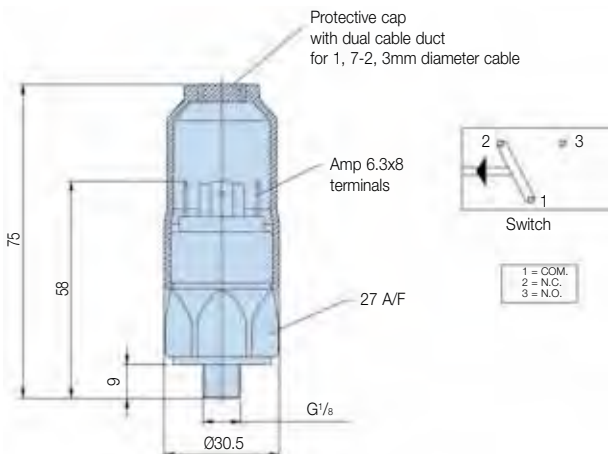

Indicator PS NO/NC pressure switch

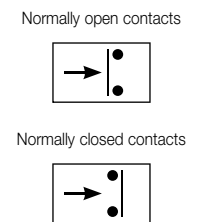
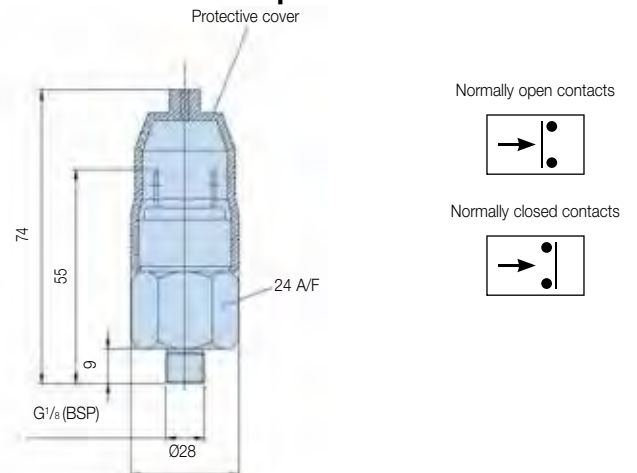

Specifications	
Elec.rating	42V / 4A
Thread connection	G1/8
Elec.connection	AMP 6.3x0.8 terminals + protective cap
Protection	IP65 (with cap) terminals IP00
Code	FMUS14EBMG02 L (Switch)

Specifications	
Elec.rating	42V / 2A
Thread connection	G1/8
Elec.connection	AMP terminal 6.3x0.8
Protection	IP65 (terminal IP00)
Switch type	NO or NC
Code	FMUS2EBMG02L (NO switch) FMUS3EBMG02L (NC switch)

Visual indicator	1.2 bar
G1/8: code	FMUG2EBPG02L